

# Heading Hints

## A Guide to Cold Forming Specialty Alloys

---



# Heading Hints

## A Guide to Cold Forming Specialty Alloys

- **Basics**
- **Materials**
- **Selection**
- **Coatings**
- **Tooling**

The information and data presented herein are typical or average values and are not a guarantee of maximum or minimum values. Applications specifically suggested for material described herein are made solely for the purpose of illustration to enable the reader to make his or her own evaluation and are not intended as warranties, either express or implied, of fitness for these or other purposes. There is no representation that the recipient of this literature will receive updated editions as they become available.

MEMBER:



MEMBER:



ISO 9002 and QS-9000 Registered  
Headquarters - Wyomissing, PA

© Copyright 2001, CRS Holdings, Inc.  
All rights reserved. 8-01/5M  
Printed in U.S.A.

# Introduction

**Heading Hints** is published by Carpenter Technology Corporation (“Carpenter”), whose Specialty Alloys Operations produces more than 400 stainless steels and specialty alloys, including numerous grades specifically designed for the heading industry.

**Heading Hints** is intended to serve as a reference source to aid in the successful fabrication of these materials in cold forming operations. Among the subjects covered are selection, lubricants and coatings, tooling and die design and manufacture, important techniques and case histories. Most of the information relates to stainless steel and high temperature alloys heading practices, but much of it is also applicable to heading other ferrous and nonferrous alloys.

While it is important to have a thorough knowledge of general cold forming procedures, virtually all applications have their unique requirements. If you have any questions about a specific application for stainless steel or high temperature alloys, or about heading and cold forming in general, please feel free to contact Carpenter’s technical service staff. Not only do we specialize in the development and production of alloys and product forms for heading, but we have also compiled a considerable amount of experience working with customers on fabrication problems which could be relevant to solving your needs.

---

## Table of Contents

<b>Chapter 1</b>	<b>Heading Basics .....</b>	<b>2</b>
<b>Chapter 2</b>	<b>Selecting the Right Stainless Steels and High Temperature Alloys for Heading .....</b>	<b>17</b>
<b>Chapter 3</b>	<b>Coatings and Lubricants .....</b>	<b>32</b>
<b>Chapter 4</b>	<b>Tooling for Heading .....</b>	<b>38</b>
<b>Chapter 5</b>	<b>Selected Hints .....</b>	<b>47</b>
	Warm Heading .....	47
	Tubular Rivets.....	48
	Hex Head Cap Screws .....	50
	Thread Rolling .....	51
	Accommodating Secondary Operations .....	52
	Calculation Methods for Upset Volumes .....	53
	<b>Glossary .....</b>	<b>56</b>



# Chapter 1

## Heading Basics

### Station 1—Cut-off

Coiled wire is fed into cold-former.  
Slug is cut off to specified length.

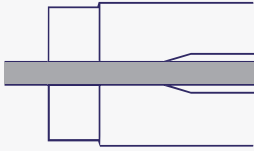

### Station 2—Squaring

Ends of cut-off are squared.

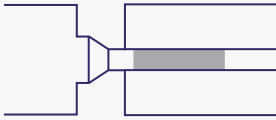

### Station 3—Impact Extrusion

Extrusion punch forces squared cut-off through die orifice forming the smaller dia.

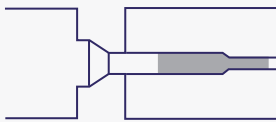

### Station 4—2nd Blow Extrusion

Shoulder is squared, and centering marks formed in ends to assist in subsequent operations.

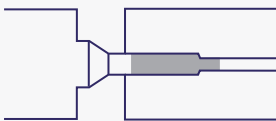

### Station 5—Backward Extrusion

Center hole is formed through backward extrusion.

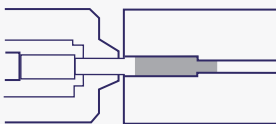

### Station 6—Forward Extrusion

Taper is formed above large shoulder.  
Two smaller shoulders are formed  
and stem is forward extruded.

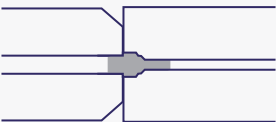

### Station 7—Finishing Blow

Large shoulder is trimmed forming sharp-cornered hexagon for wrenching.

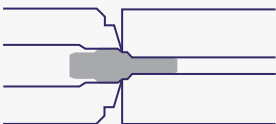

**Fig. 1** Today's sophisticated cold forming machines include as many as seven die stations. Here is one possible sequence for producing a part on a seven-die header.

### Introduction to Cold Heading

Cold heading is a cold forming process that essentially involves applying force with a punch to the end of a metal blank contained in a die. The force must exceed the metal's elastic limit (yield strength) to cause plastic flow. It may be considered a forging operation without heat. Heading includes upsetting and extruding, and is often performed in conjunction with other cold forming operations such as sizing, piercing, trimming, thread rolling, blank rolling and pointing.

Upsetting, a term used synonymously with heading, means to form a head on a fastener, or a bulge in a cylindrical part being headed. Extruding means either decreasing the diameter of the blank by pushing it through a hole, or punching a hole in the center of the blank and allowing the metal to flow backward over the punch. In both cases the volume of the metal blank remains constant; it is merely reshaped by upsetting or extruding.

Heading is a metalworking process that goes back before the turn of the century and for many years was used only to produce simple fasteners. Today heading is a high-speed, automated and multi-station operation that is capable of producing not only increasingly complex metal fasteners economically, but a growing variety of other components, including some that are asymmetrical. Combined with this dramatic improvement in heading equipment is the ability to successfully cold form parts from tougher metals, including stainless steels and high temperature alloys.

### Advantages of Cold Heading

Heading differs considerably from machining where material is actually cut away to form a finished part. In heading there is no scrap except for a minimal amount which may occur during secondary operations, such as trimming. Heading, however, is not intended to replace machining. There are many cases—very complex parts, larger parts or low production requirements—where machining is more economical. In fact, there are some materials that cannot be headed. Heading and cold forming now, however, enable more economical and faster production of many fasteners and other parts that previously could only be made with machining.

## Why Cold Heading Is On the Increase

Fasteners represent the single largest category of headed parts produced. Today, the multi-billion-dollar domestic fastener industry manufactures some 260 billion fasteners from a variety of materials. Many people are not aware that heading and cold forming are used to make a wide range of components—from spark plugs to axles. Cold heading and forming technologies continue to expand and improve.

## Recent Developments in Cold Heading/Forming

Heading and cold forming machinery is much more advanced. For example, machines are now produced with five or more dies and features to allow the production of both long and short parts. One adjustment changes the cutter, feed stroke, transfer and kickout timing functions. CNC control gives the operator instant access to production data. Quick change setups allow both punch and die components to be set up and adjusted off-line, so valuable production time is not wasted. Multi-station headers that perform a combination of upsetting, extruding and other cold forming operations have also significantly increased heading production rates and capabilities (Figure 1).

Increasing metallurgical knowledge enables the heading and cold forming of tougher materials. Specialty alloy producers like Carpenter can more closely control the analysis and manufacture of grades to meet more demanding requirements for greater corrosion resistance and strength in headed parts. Where good cold forming qualities and consistent performance are desired, it is now possible to have certain AISI grades made within controlled analysis limits to improve cold formability and subsequent secondary machining operations.

In other cases, analyses which have been modified for cold forming provide a means for the economical production of certain fastener designs. Tougher tool steels extend the life of heading dies. Producers like Carpenter also make alloys that are versatile enough to meet fabrication operations that call for both heading and machining. For example, Carpenter's 302HQ-FM® stainless combines the advantages of a popular cold heading grade (Custom flo 302HQ stainless) and a free machining grade (Project 70® Type 303 stainless). Finally, other heading practices, such as warm and hot heading, can extend the forming limits to include many of the superalloys.

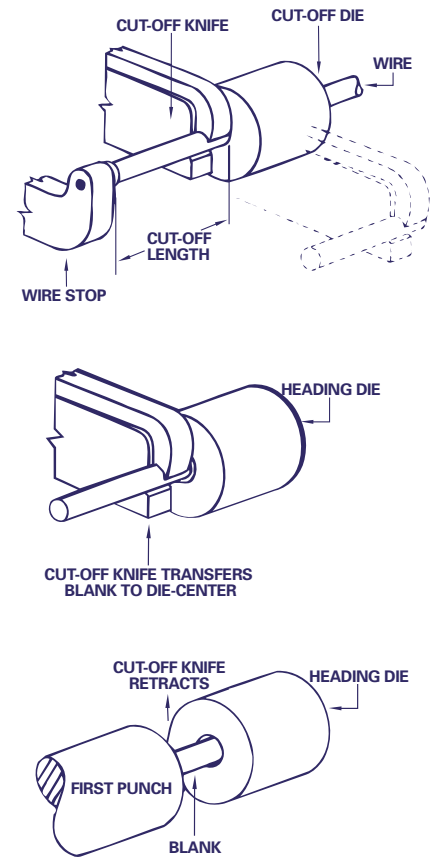

**Fig. 2** Proper cut-off of blanks in the heading machine is a critical operation since blank mass equals the mass of the finished part. Most headers use a sequence like this to cut blanks from wire coils.

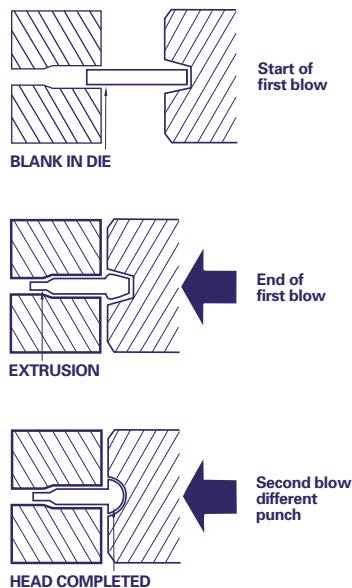

**Fig. 3** The typical one-die, two-punch method is common in producing headed parts, especially fasteners. The first blow combines partial head upset (coning) with shank extrusion, while the second blow finishes head shape.

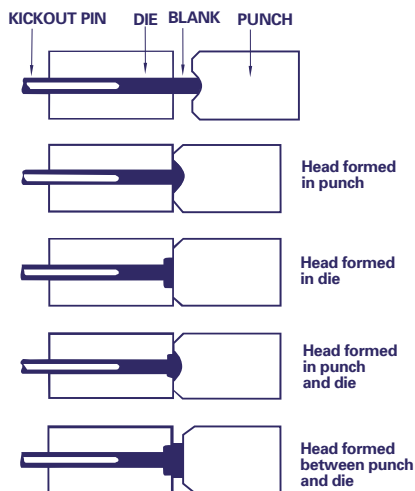

**Fig. 4** The upset of fastener heads is accomplished using one of these four methods:

1. Head formed in punch.
2. Head formed in die.
3. Head formed in punch and die.
4. Head formed between punch and die (free upset).

## How the Heading Process Works

Heading equipment primarily takes round wire in a coil form and converts the wire into desired parts at a high rate of speed.

Four basic steps comprise the heading process (Figure 2):

1. A length or blank of wire is cut from the wire coil.
2. The blank is placed in line with a cavity or die.
3. The blank is forced into a desired shape with one or more upsetting and/or extruding operations called blows.
4. The part is ejected.

This heading process may be part of a sophisticated cold forming machine that has additional points or stations where further operations—trimming, piercing or pointing—are carried out following upsetting and extruding. Most headers, however, are of the single or double blow variety. Multi-station part formers can include up to seven die stations. The part being formed is transferred from one die to another until a completed part is produced. The typical arrangement is horizontal, though some multi-station formers are arranged vertically; the part progresses from the first die station at the top to the last die station at the bottom in this case.

Forming parts on a heading machine using upsetting or extruding is not merely a matter of hammering the metal blank until the desired shape is reached.

The punch and die work together. The punch is a simply shaped hammer that strikes the blank on its end. This forces the other end into the die which produces, for example, a headed bolt (Figure 3). In a typical heading machine the punch, carried on the gate or ram, moves toward the blank with a great deal of force, striking it with an impact of many tons per square inch.

Perhaps no operation in the cold heading sequence is more important than the wire cut-off to form the blanks. This is because the volume of the finished part essentially equals the volume of the blank from which it was made. Since part dimensions and part volume are interdependent, blanks must be cut to consistent volume.

In many instances the upsetting of the blank is controlled by the punch and takes place outside the die. However, the head can also be formed in the die, in both the punch and die, or between the punch and die, a technique called free upsetting (Figure 4).

Commonly, each die station in the heading machine has two punches that oscillate to form the fastener head. The first punch action partially shapes the head and is called coning, while the second punch finishes the head.

A heading machine includes either solid dies or open dies. Solid dies are more common; open dies are used when a fastener requires a very long

shank that cannot be fabricated with a solid die. In solid die headers, the knockout (or kickout) pin is equally important to the interaction of the punch and die. The knockout pin serves as a support at the back end of the blank as the punch strikes the front end, and the knockout pin then ejects the finished part (Figure 5).

Different combinations of upsetting and extrusion blows are possible, but upsetting is generally the first blow, with an extrusion blow following. Upsetting and extrusion can take place in the same blow.

### Knockout Pin Specifics

Knockout (or kickout) pins serve two functions. They stop blanks as they enter the die at the point where upsetting is to start. For this reason pins must withstand some of the forming pressures. The second knockout pin function is to eject the headed part to clear the die for the next blank. The unsupported length of the pin should not exceed eight diameters. This is a good general rule, though some fabricators run parts with the knockout pin equivalent to 10 or 12 diameters unsupported.

When the knockout pin's unsupported length exceeds these diameters, a supported pin assembly (Figure 6) is suggested.

Lack of support isn't the only reason for pin breakage. Broken pins can result from running poorly coated wire, or wire with an incorrectly selected coating. Rough, rusted or uncoated spots on a wire make the parts more difficult to eject; this may result in pin breakage. Also, as the end of the knockout pin wears, it's possible for metal to extrude around the end of the pin. This may cause a tight spot in the die where the pin and workpiece overlap, resulting in sufficient additional pressure to break the pin. A similar effect can occur when the diameter of the pin is too large. As the pin stops the workpiece when it enters the die, it often

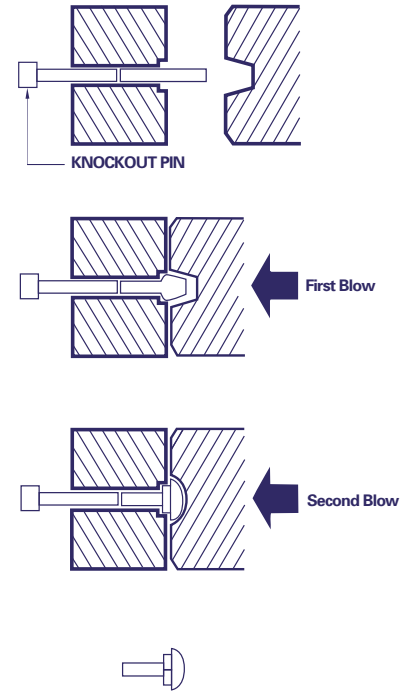

**Fig. 5** The knockout (or kickout) pin plays an important role in solid die heading. The pin acts as a blank support and also ejects finished parts.

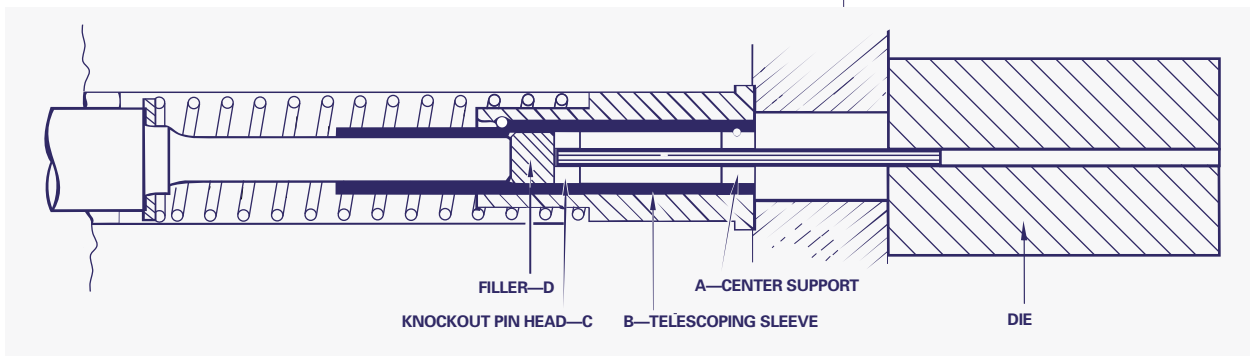

**Fig. 6** When unsupported knockout pin length must exceed 12 diameters, a supported pin assembly like this is recommended. The center support (A) reduces the unsupported length to less than 12 diameters on both sides of support.

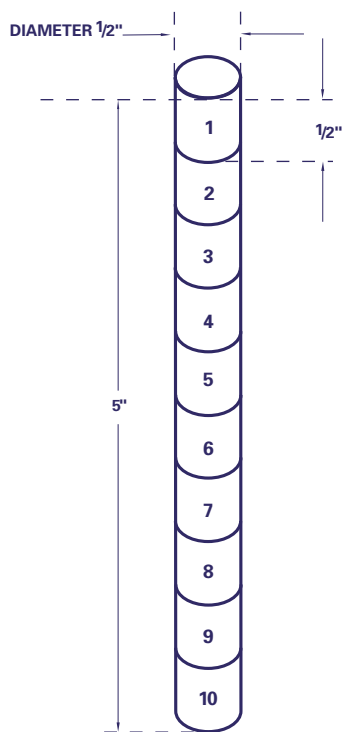

**Fig. 7** This simplified diagram shows how diameters of wire are calculated to determine upsetting limits.

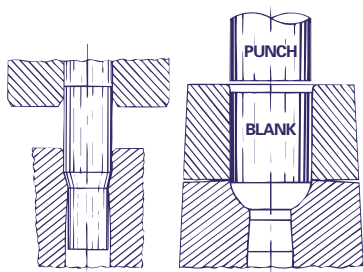

**Fig. 8** Extrusion is either open (left) in which the blank is forced under pressure into a smaller diameter die hole, or it is trapped where the blank is totally confined within the die prior to extrusion (right). Trapped extrusion permits reductions in area of up to 75 percent, while open extrusion allows only 30 percent area reduction in one blow.

absorbs part of the heading process. A pin that is too large, which means it fits the die too closely, may swell, bind in the die and break from the resulting pressure.

A back taper in the die (a smaller bore diameter at the die face than toward the kickout pin) may allow the metal to upset to a larger diameter at the end of the shank than under the head. In this instance the knock-out pin must force the larger diameter through a smaller hole during ejection. Here, excessive ejection pressure may break the pin. Machining marks left in the die can also create excessive pressure. Die bores must be smooth and rust-free.

### Controlled Upsetting

There is a limit to the amount of material that can be upset in one blow under controlled conditions. Forming a more complex part in which more metal is moved farther is better accomplished in two stages, or blows, which is why single-die, double-stroke (two punches) headers are more widely used.

Upsets are calculated on the basis of wire “diameters” (Figure 7). The length of the blank is divided by the wire’s diameter. Thus, a 5" blank of 1/2" wire is 10 diameters long; a 10" blank of 1" wire is also 10 diameters long. A rule of thumb is that in a single blow on a solid die header, the maximum amount of wire that can be upset under control is 2 1/4 diameters. Theoretically we could use approximately 1" of the 5" blank to upset into a fastener head. Most single blow heading, however, is within the 1 to 1 1/4 diameter range. With a two-blow heading sequence, up to 4 1/2 diameters can be upset.

At the moment of contact between the punch and blank, the part of the blank to be upset extends out of the die unsupported. If this unsupported length is too long, or greater than 2 1/4 diameters, the blank will simply bend over on itself when struck, which produces what is known as a cold shut defect. With our 5" blank, 1" unsupported can be upset in one blow; 2" unsupported can be upset in two blows. If an attempt was made to upset 3", it could not be controlled since this equals 6 diameters.

There are, of course, exceptions to the rule. A sophisticated header with a sliding punch that supports more of the blank allows two-blow upsets of 6 1/2 diameters. Also, in multi-station headers the number of diameters that can be upset is limited only by the available dies.

This relationship between diameters of wire and upsetting is critical. Improper calculation can mean mismatching the diameter of the feed wire with the machine’s capabilities.



## Extruding

Many cold headed parts are also extruded. Forward extrusion occurs when the metal blank is forced to enter a die diameter smaller than itself. Length is increased, while diameter is decreased. Backward extrusion involves subjecting the blank to pressure from an angular punch. Because it has no place to go, the metal literally squirts along the outer perimeter of the punch, flowing backward. Forward extrusion is used to produce bolts, screws or stepped shafts; backward extrusion is useful in forming a variety of cylindrical shapes such as nuts, sleeves and tubular rivets. Like upsetting, extrusion simply rearranges the shape of the blank and there is no loss of material.

Extrusion can be in an open or trapped (contained) manner. Open extrusion means the blank is forced into a die; trapped extrusion means the blank is totally contained within a die prior to extrusion (Figure 8).

While controlled upsetting is based on diameters of wire, extrusions are governed by the area reduction of the blank (calculated as a percentage) and the angle of extrusion. The basic ground rules for open extrusion, which is more widely used than trapped extrusion, is that the percentage of area reduction in one blow cannot exceed 30 percent. The extrusion angle (the angle the shoulder of the extrusion makes with the original blank) cannot exceed 30 degrees (Figure 9).

Area is defined as the cross-sectional area of the blank using the standard circular area formula  $A = \pi r^2$ . A blank with a cross-sectional area of 1.00 sq. in. extruded to a cross-sectional area of 0.75 sq. in. is a 25 percent reduction in area. Remember that diameter measurements, both before and after extrusion, are not directly used to calculate area reduction. The actual cross-sectional areas must be calculated by using the above formula. Successful extrusion practice also requires that the blank extend at least  $\frac{1}{8}$ " (land) into the die for proper guidance as the punch strikes.

These rules do not apply to trapped extrusion that typically allows for area reductions as high as 75 percent in one blow.

## Contained (Trapped) Extrusion

This practice is responsible for allowing headers to produce more complicated and multi-shaped parts formerly made on automatic screw machines. It's especially applicable for extruding larger diameter wire to the required shank, a method that makes it possible to increase the ratio of the head diameter to the shank diameter.

The radial extrusion die (Figure 10) is generally preferred for contained extrusion of headed parts. This type of die reduces die pressures and improves the flow pattern of the wire as it is pushed through the die.

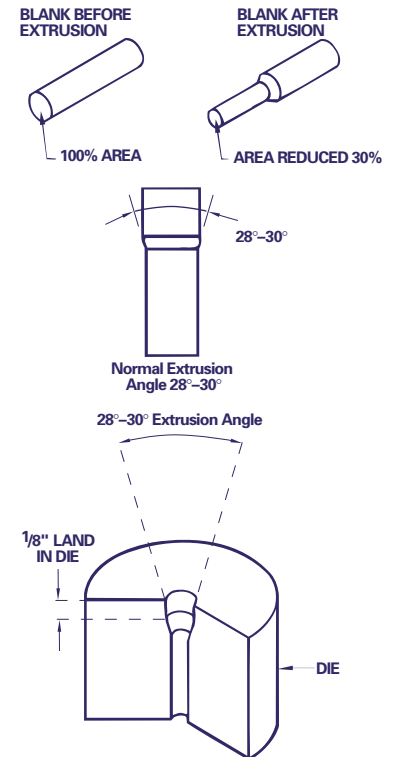

**Fig. 9** These are the elements of the basic ground rules for open extrusion.

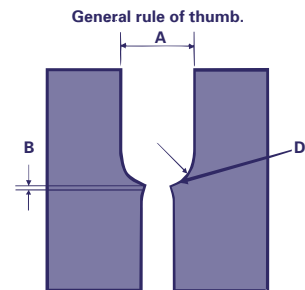

**Fig. 10** This diagram illustrates the radial extrusion die and its key dimensions.

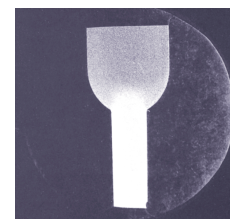

**Fig. 11** This photomicrograph shows radial flow pattern, which indicates die pressures are decreased as the outside edges flowed much more readily through the core.

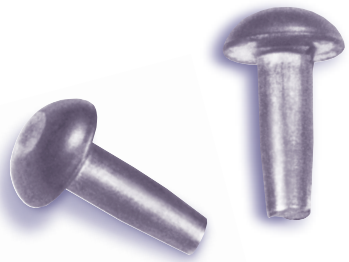

**Fig. 12** Simple upsetting was used for the screw blank on the left, while contained extrusion was used to form the part on the right.

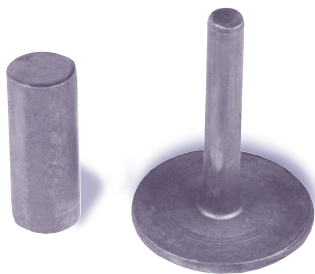

**Fig. 13** The shank of this part was trap extruded, and the head trapped and upset to produce the exaggerated head to shank ratio.

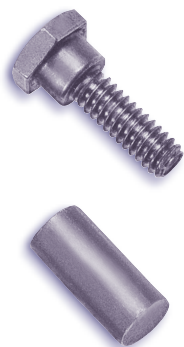

**Fig. 14** The shoulder on this part is the same size as the wire diameter, while the shank was extruded and the head upset and trimmed.

There are general rules to follow when using the radial extrusion die:

1. The blank to be extruded should be a minimum of 0.002" smaller than the die entrance.
2. The entrance length of the die should be a minimum of one-quarter blank diameter. Maximum depth is determined by the volume of stock in the upset portion and geometry of the finished part.
3. The radius is usually equal to "C" in Figure 10. This varies with the percentage area reduction.
4. The extrusion land "B" is usually 10 percent of dimension "A." This varies with die material.
5. Extrusion relief is usually a half percent of "C."
6. Break corner "D" with approximately a 45° angle leading into the extrusion land.

With any contained extrusion die, best results are often obtained by forming wire that is somewhat larger in diameter than the finished shank. Wire size is selected so that the upset dimension of the head will be about twice the original wire diameter. This wire is extruded to the shank diameter and upset to the head dimensions in the customary manner.

### Combining Upsettings and Extrusion

Multiple station machines often combine upsetting and extruding operations to form large-head, small-shank parts. The reason is that upsets can involve 6 to 10 diameters, rather than the  $4\frac{1}{2}$  diameters maximum. Upsetting and extruding, however, are separate operations, so maximum deformation of a blank must be figured separately for upsetting and extruding limits even with multi-station headers.

By starting with wire stock larger in diameter than the required shank, then extruding the shank and finally upsetting the head, maximum deformations can be reached for both extruding and upsetting based on initial stock size. For instance, a  $\frac{1}{2}$ " blank trap extruded to a reduction in area of 80 percent, and then upset 6 diameters, results in an actual upset having 70 diameters of the extruded shank size.

Since single-die, double-stroke headers (one die, two punches, two blows) are the norm in heading machines, combining upsetting and extrusion is common practice. The first blow extrudes the shank and partially forms the head; the second blow finishes the head.

An important rule for combining these two operations is that parts being formed in solid dies cannot have a shank length that exceeds 8 diameters (Figure 15). Since solid dies include a knockout pin, the knockout pin must overcome the great friction between the shank and the die as it kicks out the finished part. If more than 8 diameters of the knockout pin

are unsupported outside the die, the knockout pin will usually bend as it pushes against the blank. Shank lengths over 8 diameters are produced using an open die, a two-part die that is spread apart by a cam mechanism as the part is finished. The next blank pushes out the finished part; no knockout pin is used with open dies.

### Typical Examples

Let's assume a bolt has to be made from  $\frac{1}{4}$ " wire on a two-blow, solid-die header. If we factor in the ground rules for upsetting and extrusion, the following limits apply to making this part:

1. The maximum length in inches of metal that can be used to upset the head is  $1\frac{1}{8}$ " ( $4\frac{1}{2}$  diameters of the  $\frac{1}{4}$ " wire).
2. The maximum shank length is 2" (8 diameters of  $\frac{1}{4}$ " wire).
3. The maximum blank length is  $3\frac{1}{8}$ ", which includes  $1\frac{1}{8}$ " of material to upset the head, and 2" of material to form the shank.

Here's another example. Assume you want to produce a part like the one shown in Figure 16. First, it would be uneconomical to machine this fastener from  $\frac{1}{4}$ " stock in large numbers. Second, the part cannot be produced with conventional two-blow, solid-die heading. Here's why. A  $\frac{1}{2}$ " wire stock is required to form the head. Using  $\frac{1}{4}$ " or  $\frac{3}{8}$ " wire exceeds the  $4\frac{1}{2}$  diameters rule for two-blow upsets. However, by using  $\frac{1}{2}$ " wire, the quarter-inch shank cannot be extruded in standard fashion. The  $\frac{1}{2}$ " wire has an approximate area of 0.20 sq. in., while the  $\frac{1}{4}$ " shank has an area of 0.05 sq. in. This is an area reduction of 75 percent that exceeds the 30 percent ground rule for open extrusion. This part can be formed from the  $\frac{1}{2}$ " wire, however, on a two-die, three-blow header:

1. Trap extrude the  $\frac{1}{2}$ " shank portion, since this method allows for area reductions of up to 75 percent.
2. Transfer the part to the second die station and finish it in the normal one-die, two-punch sequence. The first blow extrudes the  $\frac{3}{4}$ " shank portion and partially forms (or cones) the head. The second blow forms the  $1\frac{1}{4}$ " diameter head.

### Warm and Hot Heading

Warm and hot heading techniques involve the heating of wire or blanks during certain stages of the heading process and allow forming of more heavily alloyed metals, including precipitation hardening stainless steels and high temperature alloys. To assist in forming parts such as recessed-head screws from tougher metals, wire can be heated before it enters the header. This reduces yield and tensile strengths to improve forming characteristics.

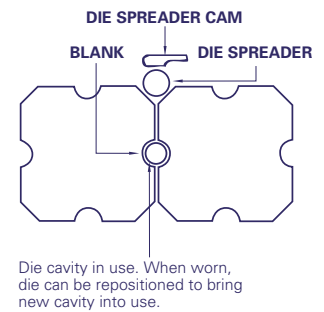
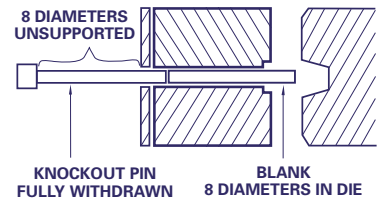

**Fig. 15** Solid-die shank extrusion cannot exceed eight diameters, which means the knockout pin cannot be unsupported outside the die for more than 8 diameters. Shanks longer than 8 diameters are extruded with an open die, shown on the bottom.

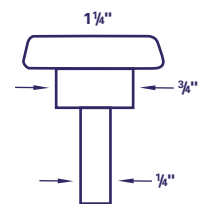

**Fig. 16**

Warm heading in the metallurgical sense is really cold heading since the metallurgical structure is not affected; the material is simply made more ductile. With hot heading, however, the metallurgical structure of the material is often altered. In both instances, less pressure is required to make the metal flow plastically since warm and hot heading techniques lower material strength and increase ductility.

Warm heading has been applied successfully in forming stainless steels and high temperature alloys such as Carpenter Pyromet® A-286 alloy and Greek Ascology. Heating is most effective in the 350° to 450°F (177° to 232°C) temperature range. While warm or hot heading is not normally required for highly headable stainless grades such as Custom Flo 302HQ or Type 430, it may be used with these metals to improve metal flow and avoid stress cracking in severe upsets.

Warm heading is accomplished by heating the wire before it enters the feed rolls or, when possible, between the feed rolls and the heading machine. Three types of heating methods are usually used—resistance, gas or induction.

Hot heading, on the other hand, means heating the wire to the 1100° or 1200°F (593° or 649°C) temperature range. It's almost equivalent to forging.

Proper choice of lubricants is essential for effective warm and hot heading. (See Chapter 3.)

For additional hints for warm heading, see Chapter 5.

### **Types of Heading Machines**

Many types of heading machines are available and they combine standard and special tooling to carry out a variety of heading and cold forming operations and sequences. Some weigh as much as 500,000 pounds and have seven die stations. Since only so much metal can be formed in one blow, the number of dies and wire diameter acceptance range are usually used to describe machine types. Typical measurements cover wire diameter, blank length and heading force.

Specifications for a typical solid-die header may be:

Max. Diameter Wire =  $\frac{1}{4}$ " (Force available at cut-off knife for shearing).

Max. Shank Length = 2" (Approximately 8 times wire diameter).

Max. Wire Cut-off Length =  $3\frac{1}{8}$ " (About 12 times rated wire diameter).

Max. Pieces per Minute = 125 (Optimum machine rotation speed).

Max. Heading Capacity = 50 tons (Force required to upset a carriage bolt of the rated wire diameter wire, in this case  $\frac{1}{4}$ ").

Machine specs tend to be conservative. It is best to discuss questions about machine capabilities, or which type of header to purchase, with the manufacturer.

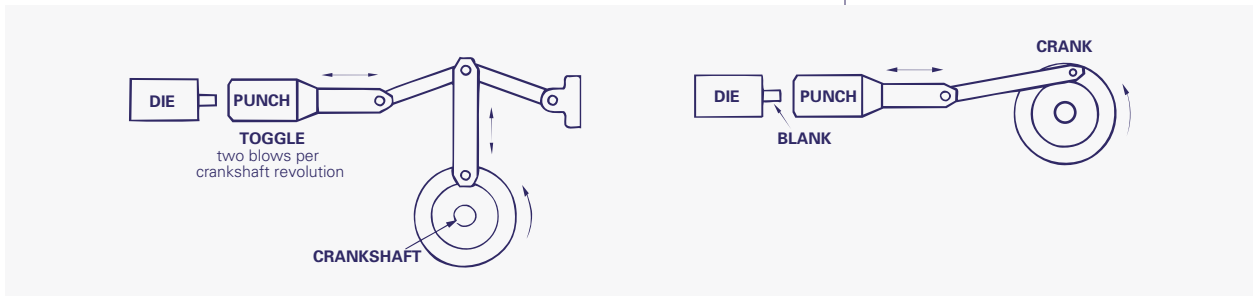

**Fig. 17** The gate (ram) on the heading machine is toggle or crank operated. The toggle machine (left) allows two forward strokes per machine revolution, while the crank allows one. Most agree that neither has a definite advantage.

Heading machines are divided into two basic types, crank and toggle headers (Figure 17). The toggle type, the older version, provides a mechanical advantage and gives two forward strokes per machine revolution. The crank machine is capable of one blow per revolution. Neither is considered to be more advantageous. The toggle type is used to produce simpler parts, while the crank version, which is more prevalent today, is used for more complex forming.

These are the common machines available:

**Single-Stroke:** Has one die, one punch. These are used to make simple parts that can be formed in one blow. Ball headers are a variation of this type. Production rates up to 600 parts per minute are possible.

**Single-Die, Double-Stroke:** Considered the most versatile and widely used machine. It includes one die, two punches, and produces most screw blanks and other fasteners. Wire capacity ranges up to  $\frac{3}{4}$ " diameter. Production up to 450 parts per minute. Some double-stroke headers are custom designed for tubular rivet production.

**Three Blow, Two Die:** Includes two dies and three punches, and has the same basic design as the double-stroke header. It offers an added advantage of extruding or upsetting in the first die, with double-blow heading, or heading and trimming in the second die. It's used to produce large-head small-shank fasteners, or parts requiring trapped extrusion and upsetting. It's also excellent for making stepped-diameter parts where transfer between dies would be difficult.

**Progressive or Multi-Station:** These are equipped with as many as seven die stations; most are two- to five-die machines with an identical number of punches. A simple transfer mechanism moves workpieces from the cutter through successive dies. Multiple upsetting blows, combined with extruding, piercing and trimming, make these machines ideal for long shank parts production. They can accommodate materials up to an inch in diameter with under-the-head parts lengths of up to nine inches.

## Proper Machine Setup

There are several fundamental and critical points for proper heading machine setup. These include:

**Material Selection**—Regardless of the wire, adequate records are essential. Careful documentation includes writing down the lot number, heat number, wire condition and previous results. Save the original wire tag and apply it to any coil remainder.

**Feeding**—Properly sized feed rolls are important, yet often overlooked. With the wrong size rolls, several problems can occur. Galling may result during the heading stage with out-of-round wire; wire surface can be scratched; and slippage, resulting in short feeds, often comes with improper machine timing and tool alignment. The latter also means excessive tool breakage.

**Quill**—Good quill design calls for complete elimination of obstructions in the I.D. Sharp corners should be avoided. The inside bearing surface is usually just large enough to permit the wire to fit easily without being “sloppy.” Excessive I.D. clearance will create a poor shearing action that results in a burr on the cut-off blank. This, in turn, causes problems in the heading stage.

**Shearing**—To produce consistent cleanly cut blanks, the cut-off knife should be made from a highly wear-resistant steel. Carpenter No. 610® alloy, a high-carbon, high-chrome tool steel, has been used in such applications.

**Wire Stop Nib**—The nib should have a hard, square contact surface to provide for maximum wear resistance without causing burr formation.

**Wire Feed Setting**—Adjust this to provide a full cut-off blank with each stroke. But avoid excessive over-travel. This actually inhibits clean cut-off and causes problems at subsequent stations.

**Boltmakers:** These are three- and four-die headers that combine heading, trimming, pointing and threading in the same machine. Materials up to 1½" in diameter are used, and production rates vary up to 300 pieces per minute. Boltmakers produce completely finished hexagonal and socket capscrews, as well as a number of other special threaded parts.

**Cold Nut Formers:** Standard or special nuts are run on this machine with five die stations. A simple transfer mechanism rotates the blanks end-for-end between successive dies, which allows for working of the metal on both sides to produce high quality nut blanks. Center plugs are easily reclaimable, so there is very little material waste. Nuts an inch or larger are run on this machine.

**Cold Formers:** Four, five or six die stations and a variety of transfer mechanisms make these the most versatile heading machines. Forming operations for making odd-shaped parts can be combined on this one machine. They are set up to feed wire, bar or blanks, and can form metal cold or warm. Materials in the 2" diameter and larger range can be run. Multiple upsetting blows combined with extruding, piercing and trimming operations make cold formers ideal for producing long shank or specially designed components.

All the above machines have five basic operations—upsetting, extruding (forward and backward), trimming and piercing. Other related operations like swaging, coining or embossing can also be performed. Since all heading machines include a predetermined number of die stations or operations, the design of parts must match equipment capabilities.

## Materials That Can Be Headed

Although at one time it was felt cold heading techniques were somewhat limited to ductile materials with low work hardening rates, that is no longer the case. With today's more advanced equipment, techniques and tooling, higher strength materials like the stainless steels and high temperature alloys are routinely being cold headed. A number of stainless steels are produced with modified compositions to provide lower work hardening rates. (See Chapter 2 for details on the proper selection of materials.)

## Formability Considerations

Strength of materials is the determining factor in the ease of cold forming. The yield and tensile strength of an alloy governs formability. Yield strength is the point at which the metal begins to deform permanently; tensile strength is the point at which the metal begins to tear apart. Plastic flow occurs when the force applied exceeds the material's yield strength. If the metal is stressed beyond its tensile strength during forming, the blank splits, cracks or breaks. The range in which a metal can be cold worked lies between its yield and tensile strength values.

Tensile strengths (ultimate strengths) found in most technical literature differ from the actual strengths of the materials being formed in the header. These strengths, therefore, must be considered in cold forming. The strength of a material is affected by both the temperature at which it is being formed and by the speed with which it is being formed. It is also affected by the geometry of the part being made.

What occurs physically with materials during the heading process is very complex. While it can be frustrating, for example, when trying to determine exactly why certain materials may crack, it is comforting to know that modern technology is addressing this problem. CAD/CAM techniques are being employed to more accurately predict and control what happens to materials in the headers. Software packages are available that can allow design engineers or operators to precisely determine if slowing the part production rate per minute would eliminate cracking problems.

Cold worked metal work (or strain) hardens due to a reorganization of its microstructure. A series of cold forming operations means both the yield strength and tensile strength increase. However, the yield strength increases faster than the tensile strength, which narrows the metal's formability range mentioned above. Depending on the type of metal, this range can become so narrow that further attempts to cold work the metal result in fracture.

Work hardening accounts for the increased strength of formed parts, and there is an associated increase in tooling pressure required to deform them. The standard grades designed for cold heading take into account the desirability of low cold working rates. (See Chapter 2.)

### **Wire Considerations**

An important part of good cold headability is the soundness of the wire. Sound centers are promoted by close controls during Carpenter's melting and hot working operations. In addition, a thorough billet inspection for surface defects is important. Quality wire offers fabricators consistent, lot-to-lot uniformity; excellent formability; optimum cut-off results; controlled sizes in a wide range of diameters; close tolerances and uniform coils; and superior surfaces.

A broad range of wire sizes and alloy types are available to match expanding cold-forming opportunities. As a leading domestic producer of headable alloys and product forms, Carpenter manufactures a number of different alloys in standard wire sizes up to 1.00" in diameter. The majority of headed parts are made from wire in the 0.062" to 0.750" diameter range.

Equally important is the capability of the producer to match specific fabricator needs. Carpenter produces wire in three basic conditions: hot rolled annealed, cold drawn annealed, and annealed cold drawn. Cold

## Advantages of Heading

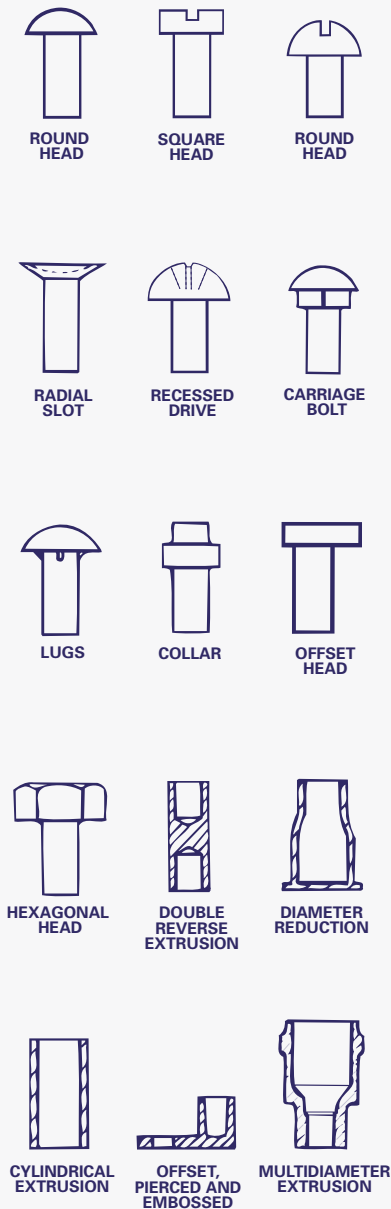

**Fig. 18** A wide range of designs is possible for cold headed parts.

finished wire is ready for the heading operation and the manufacturer controls the consistency and tolerances. Wire ready-for-redraw and hot rod receive less processing at the mill and so have more variation in size, mechanical properties and finish. With that in mind, the heading shop assumes a greater share of responsibility for product quality in return for reduced material cost. Many headers prefer annealed, cold finished wire since it can go right into the header for production. Others prefer partially finished wire because they have drawing capabilities in line with their heading operation and want more precise control of the wire diameter.

**Design Versatility:** Cold heading or forming opens unlimited possibilities to the part designer:

1. Cold forming allows use of high strength parts to be produced from non-heat-treatable alloys.
2. Cold forming is often the most cost effective way to produce complicated configurations compared with profile milling, electric discharge machining, hobbing or chemical etching.
3. Cold forming has inherent capabilities for greater strength and high production rates.

Designers can, and should, rely on the expertise of cold forming production people who are most familiar with machining capabilities. Extruding, for example, is an efficient and highly economical method for creating two or more different diameters on a part. With backward extrusion, the designer has an excellent way to form tubular shapes, including those produced with double reverse extrusions. Some part configurations achievable with cold forming are indicated in Figure 18. Multi-station headers also contribute to the designer's ability to produce a component that requires closely allied cold forming operations.

**Variety of Sizes, Shapes, Part Complexity:** Economically produced, cold formed parts today include bolts, studs, screws, rivets, special fasteners, cams, valves and many other components requiring the diameter of the head to be substantially larger than the shank. Total upsetting of the blank also is performed on cold headers to mass produce nuts and balls for ball bearings. Symmetrical parts are the easiest to cold form and cylindrical parts require only that a transfer mechanism move them from one die to another. Asymmetrical parts require positioning at each station, which calls for close cooperation between the product designer and tool engineer.

**Tolerances:** Tolerances vary with the style of the upset and, as with any other manufacturing process, closer tolerances require greater cost and precision. Diameter tolerances in cold forming operations are easily held within acceptable limits for standard fasteners. Tolerances are naturally affected by tool wear, so a check on die wear is mandatory when running parts with tighter tolerances.



**Positive Metallurgical Effects:** A primary advantage of cold forming is maximization of metallurgical properties in the finished part. The upset process actually causes the metal to flow along the axis of the blank; the grain structure is rearranged in the process to follow the contour of the part (Figure 19). This new grain structure supports the part and adds strength to it. Cutting, on the other hand, weakens grain structure. Metal cut away from underneath a bolt head means cutting the grain structure at the same time, so the bolt head is now weaker than the stock from which it was cut.

Cold heading involves working of the metal far below its recrystallization temperature. Existing grains are worked and no new grains are formed. This improves strength, hardness, toughness and fatigue resistance. Cold worked grains are usually finer than in hot-forged parts and the grain flow lines established by the various cold forming operations remain uninterrupted in the finished part. The result is enhanced strength at critically stressed corners. This metallurgical advantage often allows headed parts to be smaller without sacrificing properties.

**High Production Rates, Repeatability:** Today's headers can turn out parts at a rate as high as 100 times greater than that achievable with machining. While production rates are controlled by part size and complexity, heading and cold forming machines are automated production lines that take raw material and convert it to finished parts, ready for use. In a multi-station header where all the die units are working in unison, a finished part is ejected with every stroke. With good die design, low temperature and good lubrication, repeatability is excellent.

**Material Savings:** Cold forming is a type of "chipless machining." Parts are produced to net or near net shapes. The only waste comes from piercing and trimming. Heading scrap losses average from one to three percent, while turning or forging can produce scrap losses as high as 75 percent. An excellent example of material savings occurs in the cold forming of spark plug bodies. Prior to using cold forming, the pieces were cut with scrap losses averaging 74 percent. Now, the bodies can be cold formed 10 times faster and with scrap losses of only six percent.

The weight of a finished part that is headed can generally be held within  $\pm 1$  percent when required, or to even  $\pm 0.2$  percent when more precise cut-off is used to produce blanks. Oftentimes further machining is not required, and on many jobs cold forming eliminates secondary grinding.

**Finished Quality:** Longer part life is a benefit of cold formed parts since the controlled flow lines offer added resistance to impact, fatigue and shear failure. Cold forming means improved surface finishes. Extruding may improve surface finish from 10 to 100 micro inches and upsetting results in high quality finishes when the part is confined in the tooling or comes in contact with tooling surfaces. High quality finishes result when a high quality wire feed stock is used.

**Fig. 19** Heading improves the finished part's grain structure by making it conform to the flow of the design. The machined fastener on the bottom indicates how metallurgical structure is weakened by operations that cut across flow lines.

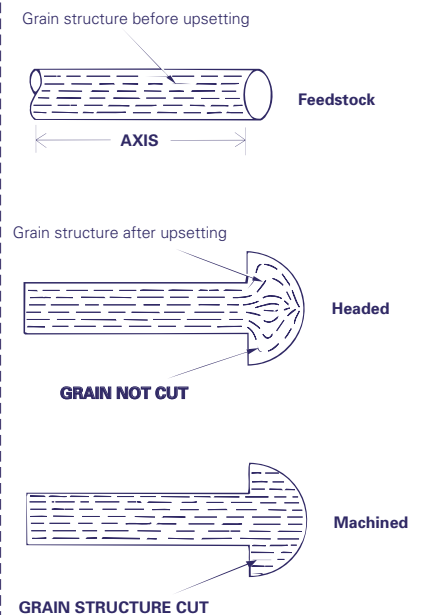

### **Disadvantages of Heading**

Heading, like any other metalworking process, has its limitations.

Relatively simple designs that can be produced on standard one- or two-blow headers usually require a minimum quantity of about 5,000 parts to cover tooling costs and set up. Complex parts that call for multiple dies, development work and other procedures usually require a quantity of at least 25,000 to 30,000 pieces. Larger or more complicated designs may not lend themselves to cold forming, but require machining instead. Some materials, because of their exceptionally high strength levels, may exceed the formability range limits for cold forming.

## Chapter 2

# Selecting the Right Stainless Steels and High Temperature Alloys for Heading

### Introduction

Stainless steels and high temperature alloys for cold heading offer today's fastener producer or manufacturer of headed components an important opportunity for increasing productivity and profits. A growing variety of headable specialty grades are readily available from Carpenter as high quality wire in several conditions and with a variety of coatings designed for virtually all cold forming, upsetting and extruding operations.

Carpenter, working closely with the cold heading industry, has improved the headability of its heading grades over the years through tight analysis control, special alloy additions and improved manufacturing processes. Quality wire for feedstock is available fully cold finished or in partially finished conditions to match a fabricator's particular manufacturing capabilities. Additional gains have been made with improved coatings (see Chapter 3), better methods of selecting headable stainless steels and the improved capability of heading equipment.

More and more applications, particularly those in which components are subject to harsh environments, high operating temperatures and great pressures, require the corrosion resistance and strength of stainless steels and high temperature alloys.

Selection, wire quality, fabricating techniques, coatings and costs are basic concerns shared by all headers.

### Alloy Selection

Selecting the right stainless steel or high temperature alloy for a heading job presents no problem if the fastener manufacturer meets required material specifications. If none are provided, the best headable alloy may be determined by means of an orderly, four-step selection process.

In order of importance, the following questions should be answered:

1. What level of corrosion resistance is required?
2. What strength is needed, bearing in mind that mechanical properties may be affected by heading or subsequent heat treatment?
3. Which of the grades meeting corrosion and strength requirements has the best headability?
4. What is the availability of the alloy selected?

In addition, two other variables should be considered. One is the part complexity, which determines the severity of upset or extrusion. The other is the heading wire coating which, particularly in the case of an alloy

## Stainless Steels

Properties are typical for batch annealed product. Strand annealed properties are higher.

Alloy (UNS No.)	Alloying Elements	Typical maximum tensile strength as annealed or overaged		Typical maximum tensile strength 5% cold worked	
		ksi	MPa	ksi	MPa
409Cb (S40940)	0.06 C max; 1.00 Mn max; 0.045 P max; 0.04 S max; 1.00 Si max; 10.50-11.75 Cr; 0.50 Ni max; (10 x C min.)/ 0.75 Cb	70	483	80	552
430 (S43000)	0.12 C max; 14.00-18.00 Cr	75	517	86	593
410 (S41000)	0.15 C max; 11.50-13.50 Cr	78	538	90	621
TrimRite® (S42010)	0.15/0.30 C; 1.0 Mn max; 1.0 Si max; 0.04 P max; 0.03 S max; 13.50/15.00 Cr; 0.25/1.00 Ni; 0.40/1.00 Mo	90	621	95	655
No. 10 (384) (S38400)	0.08 max; 15.00-17.00 Cr; 17.00-19.00 Ni	78	538	83	572
302HQ (S30430)	0.08 C max; 2.00 Mn max; 0.045 P max; 0.03 S max; 1.00 Si max; 17.00/19.00 Cr; 8.00/10.00 Ni; 3.00/4.00 Cu	75	517	83	572
302HQ-FM® (S30431)	0.06 C max; 2.00 Mn max; 0.040 P max; 0.14 S max; 1.00 Si max; 16.00/19.00 Cr; 9.00/11.00 Ni; 1.30/2.40 Cu	85	655	93	641
305 (S30500)	0.12 C max; 17.00-19.00 Cr; 10.00-13.00 Ni	83	572	93	641
316 (S31600)	0.08 C max; 16.00-18.00 Cr; 10.00-14.00 Ni; 2.00-3.00 Mo	85	655	95	655
431 (S43100)	0.20 C max; 15.00-17.00 Cr; 1.25-2.50 Ni	105	724	115	793
304/304 Mod. (S30400)	0.08 C max; 18.00-20.00 Cr; 8.00-11.00 Ni	93	641	95/100	655/689
204-Cu	0.15 C max; 6.50-9.00 Mn; 15.50-17.50 Cr; 1.50-3.50 Ni; 0.05-0.25 N; 2.00-4.00 Cu	100	689	110	758
321 (S32100)	0.08 C max; 17.00-19.00 Cr; 9.00-12.00 Ni; Ti (5 x C min)	93	641	100	689
347 (S34700)	0.08 C max; 17.00-19.00 Cr; 9.00-13.00 Ni; Cb + Ta (10 x C min)	93	641	105	724
20Cb-3® (N08020)	0.07 C max; 2.00 Mn max; 1.00 Si max; 19.00/21.00 Cr; 30.00/38.00 Ni; 2.00/3.00 Mo; 3.00/4.00 Cu; Cb + Ta (8 x C min/1.00% max)	105	724	115	793
15-7PH (S15700)	0.09 C max; 1.00 Mn max; 0.04 P max; 0.03 S max; 1.00 Si max; 14.00-16.00 Cr; 6.50-7.75 Ni; 2.00-3.00 Mo; 0.75-1.50 Al; Fe balance	130	896	145	1000
15Cr-5Ni (S15500)	0.07 C max; 1.00 Mn max; 0.04 P max; 0.03 S max; 1.00 Si max; 14.00-15.50 Cr; 3.50-5.50 Ni; 2.50-4.50 Cu; 0.15-0.45 Cb+ Ta; Fe balance	135	931	145	1000
Custom 450® (S45000)	0.05 C max; 14.00-16.00 Cr; 5.00-7.00 Ni; 1.00 Mn max; 1.00 Si max; 0.03 P max; 0.03 S max; 0.50-1.00 Mo; 1.25-1.75 Cu; Cb (8 x C min)	145	1000	155	1069
Custom 455® (S45500)	0.05 C max; 0.50 Mn max; 0.040 P max; 0.030 S max; 0.50 Si max; 11.00/17.50 Cr; 7.50/9.50 Ni; 0.80/1.40 Ti; 0.10/0.50 Co and Ta; 1.50/2.50 Cu; 0.50 Mo max	150	1034	160	1103
Custom 630 (17Cr-4Ni) (S17400)	0.07 C max; 15.50-17.50 Cr; 3.00/5.00 Ni; 3.00/5.00 Cu; Cb+Ta 0.15-0.45; 1.00 Mn max; 0.04 P max; 0.03 S max; 1.00 Si max	150	1034	160	1103
PH13-8Mo* (S13800)	0.05 C max; 0.10 Mn max; 0.01 P max; 0.008 S max; 0.10 Si max; 12.25-13.25 Cr; 7.50-8.50 Ni max; 0.90-1.35 Al; 2.00- 2.50 Mo; 0.01 N max	150	1034	165	1138
440C (S44004)	0.95/1.20 C; 1.00 Mn max; 0.040 P max; 0.03 S max; 1.00 Si max; 16.00/18.00 Cr; 0.75 Mo max	115	793	135	931

\*Trademark of Armco, Inc.

not easily headed, is essential in facilitating forming and obtaining reasonable tool life.

### Alloy Classes

Before considering corrosion resistance as a selection requirement, a review of the stainless steel and high temperature alloy classes may be helpful.

The simplest stainless steels contain a minimum of about 11 percent chromium, in addition to iron. They are generally known as the AISI 400 series of stainless steels. Depending on the chromium and carbon contents, they may be martensitic or ferritic. The martensitic alloys, typically containing more than 0.08 percent carbon, are hardenable by heat treatment. Type 410 stainless is a typical grade.

Increasing chromium or reducing carbon results in a ferritic stainless steel, which is non-hardenable by heat treatment. Type 430 stainless is a typical alloy in this family. Increasing chromium also improves corrosion resistance. Therefore, Type 430 stainless (18 percent chromium) is more corrosion resistant than Type 410 stainless (12 percent chromium).

For more significant improvement in corrosion resistance, a switch to the AISI 300 series is required. Nickel is the important alloying element in the 300 series, which includes types such as Custom Flo 302HQ, 304 and 305 stainless steels.

**Fig. 20** Analysis and properties of the most commonly headed stainless alloys. Each group is listed in order from easiest to form to most difficult to form.

These grades are the 18-8 stainless steels, containing about 18 percent chromium and a minimum of 8 percent nickel. They are austenitic and nonhardenable by heat treatment, but do work harden by cold working. Molybdenum may be added for greater resistance to chloride pitting (Type 316). Still other alloying elements may be added to enhance the alloys' fabrication characteristics. For example, Custom Flo 302HQ contains 3 to 4 percent copper, which lowers the alloy's work hardening rate and thus improves headability.

A recent alternative to 18-8 stainless is Type 204-Cu. This 200 series austenitic alloy is a low-nickel alternative to Type 304. Although properties are similar to that of Type 304, this alloy's cost is virtually unaffected by fluctuations in market nickel prices. The alloy contains 3 percent copper which significantly lowers its work hardening rate and improves headability. The high nitrogen content is necessary to maintain the austenite structure and results in a higher annealed yield and tensile strength than Type 304.

Another stainless steel category covers the age-hardening or precipitation-hardening alloys such as Custom 450<sup>®</sup> stainless, Custom 455<sup>®</sup> stainless and Custom 630 (17Cr-4Ni) stainless. They provide corrosion resistance at a strength level unavailable in the 300 or 400 series stainless steels.

A separate group comprises the high temperature alloys. Included in this classification are grades such as Pyromet<sup>®</sup> Alloy 718, Pyromet Alloy A-286 and Waspaloy. These alloys, like the precipitation-hardening grades, involve much more specialized heading techniques and require considerably more energy to head.

Another material used in specialized applications is Carpenter Ni-Cu alloy 400. This is an alloy with relatively high strength and toughness over a wide temperature range. Ni-Cu alloy 400, with its very low work hardening rate, is easy to head.

High Temperature/Specialty Alloys						
Properties are typical for batch annealed product. Strand annealed properties are higher.						
Alloy (UNS No.)	Alloying Elements	Typical maximum tensile strength as annealed		Typical maximum tensile strength 5% cold worked		
		ksi	MPa	ksi	MPa	
Ni-Cu Alloy (N04400)	0.3 C max; 2.0 Mn max; 0.5 Si max; 0.024 S max; 63.0/70.0 Ni; 2.50 Fe max; Cu balance	75	517	84	579	
Pyromet <sup>®</sup> A-286 (K66286)	0.08 C max; 2.00 Mn max; 1.00 Si max; 13.50/16.00 Cr; 24.00/27.00 Ni; 1.00/1.75 Mo; 1.90/2.30 Ti; 0.10/.50 Va; 0.35 Al max; 0.003/0.010 B; Fe balance	95*	655	95*	655	
Pyromet 718 (N00718)	0.08 C max; 0.35 Mn max; 0.35 Si max; 0.015 P max; 0.015 S max; 17.00/21.00 Cr; 50.00/55.00 Ni + Co; 1.00 Co max; 2.80/3.30 Mo; 4.75/5.50 Cb + Ta; 0.65/1.15 Ti; 0.35/0.80 Al; 0.001/0.006 B; 0.15 Cu max; Fe balance	120*	827	135*	931	
Waspaloy (N07001)	0.02/0.10 C; 0.50 Mn max; 0.75 Si max; 0.020 S max; 18.00/21.00 Cr; 3.50/5.00 Mo; 12.00/15.00 Co; 2.75/3.25 Ti; 1.20/1.50 Al; 0.02/0.12 Zr; 0.003/0.008 B; 0.10 Cu max; 2.00 Fe max; Ni balance	130*	896	140*	965	
Pyromet 882 (T20881)	0.40 C; 1.00 Si; 5.00 Cr; 1.50 Mo; 0.40 V; Fe balance	95	655	100	689	

\*Dependent upon grain size and heat treated mechanical property requirements.

**Fig. 21** Analysis and properties of the most commonly headed high temperature/specialty alloys. Each group is listed in order from easiest to form to most difficult to form.

**Fig. 22** Popular cold headable stainless steels have these typical work hardening rates.

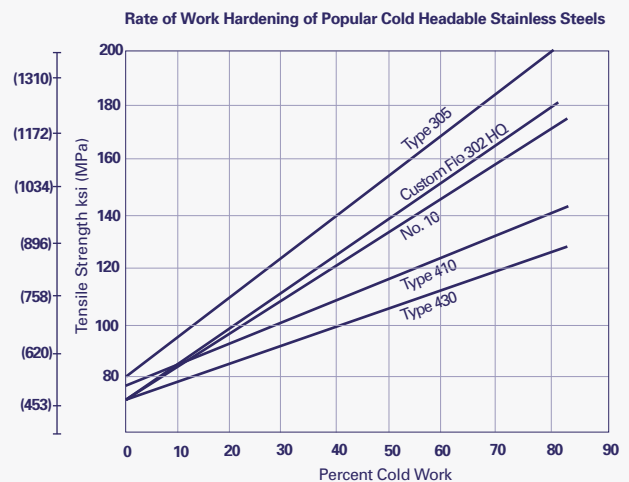

Alloy	Typical max. tensile, 5% cold work		Typical work hardening rate*
	ksi	MPa	
430	86	593	0.7
410	90	621	0.9
No. 10	83	572	1.4
302HQ	83	572	1.5
305	93	641	1.5
316	95	655	1.6
304	95	655	1.6
304 Mod.	100	689	1.8
204-Cu	110	758	1.6

\*Increase in tensile strength (ksi) for each percent of reduction of area through cold working.

**Fig. 23** Relative headability of common stainless steels based on typical maximum tensile strength and work hardening rates.

### Determining Headability

Heading, of course, is forming the head on a fastener by upsetting. Headability is determined by the alloy's mechanical properties and work hardening rate which, in turn, reflects the rate at which those mechanical properties are increased by cold working.

Tensile strength alone is not indicative of headability because two different alloys with the same annealed tensile strength may have different work hardening rates. If the two materials are cold worked by inline drawing, the one with the higher work hardening rate will end up with a higher yield and tensile strength. Thus it will be more difficult to head because more force will be required to shape the part.

Headability depends heavily on the ratio of yield strength to ultimate tensile strength. Yield strength must be exceeded before material flow can occur, but the ultimate tensile strength cannot be exceeded or the part will crack.

An alloy's chemical composition determines its work hardening rate. The compositions and properties of the headable stainless steels and high temperature alloys are shown in Figures 20 and 21, in descending order from easiest to head to most difficult to head.

Stainless grades in the 400 series cold head much like carbon and low alloy steels. Type 430 stainless is the easiest to head, and Type 440-C stainless the most difficult. Although Ni-Cu 400 alloy is shown under the High Temperature/Specialty Alloys section, its headability is comparable to that of Type 430 stainless.

The 300 series provides more challenges than the 400 series since alloys in the 300 group have a higher work hardening rate (Figures 22 and 23). Stainless steels in the 300 series require more energy to head than those in the 400 series. Carpenter No. 10 stainless and Custom Flo 302HQ stainless have the lowest work hardening rates of the 300 series steels, and therefore are the easiest to head.

Although Type 304 Modified is less headable than Type 304, its high work hardening rate is an asset for fasteners requiring high strength threads. Type 304 Modified can be cold worked to about Rc 40-45. The alloy has been used in construction type fasteners.

As might be expected, the precipitation-hardening stainless steels and high temperature alloys are generally more difficult to head due to alloying elements that impart overall greater strength at cold working temperatures.

In the case of PH stainless steels, optimum formability is usually obtained if the material is used in the overaged condition. For example,

Custom 630 (17Cr-4Ni) stainless has the lowest yield strength and tensile strength and therefore best formability when in the H1150M condition. Material processed by this method must be subsequently solution treated before aging to get maximum tensile strength.

Some stainless steels are made that offer cold headers maximum fabricability characteristics for components that require secondary operations like machining. Carpenter 302HQ-FM® stainless is a good example of how certain grades can be modified

to meet specific property requirements. This alloy combines the headability of Type 302HQ stainless with the free-machining benefits of Type 303 stainless.

It can be cold headed into a variety of parts, then easily machined in secondary operations like drilling, slotting and tapping.

Type 409Cb has been extensively used in the automotive industry for muffler hangers and brackets, antenna wire, catalytic converter weld wire and in oxygen sensor components. Type 409Cb-FM, a free-machining variation, has been used where secondary machining operations are required.

Advances in steel making technology now make it possible to modify composition and processes to meet more specific application needs. When such modification is desired, the usual caveat applies: the volume of usage must justify the necessary developmental work.

### Selection Method

To simplify selection of the best alloy for a heading job, Carpenter has developed a proprietary method which plots relative corrosion resistance and headability of the materials most commonly used. Figure 24 shows a diagram which positions 16 stainless steels and high temperature alloys in accordance with these two key characteristics.

Using this diagram, simply move up for better headability, or to the right for better corrosion resistance. The drawing indicates that Type 430 stain-

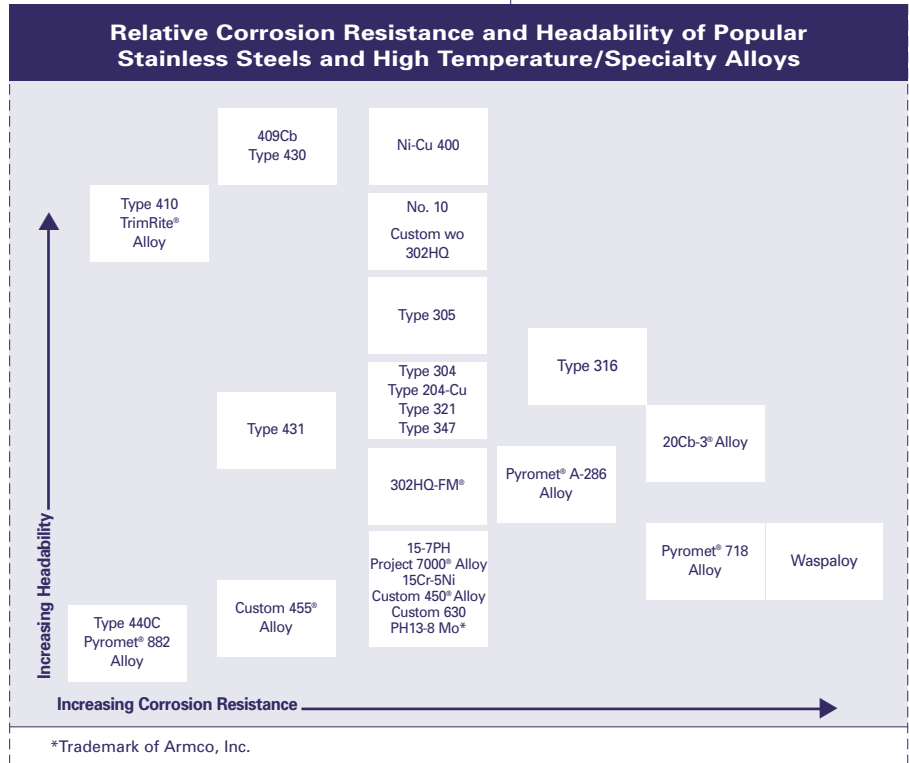

**Fig. 24** Relative corrosion resistance and headability characteristics of commonly headed stainless steels and high temperature/specialty alloys.

less and Ni-Cu alloy 400 have the best headability, while Waspaloy has the highest corrosion resistance. No. 10 and Custom Flo 302HQ offer a good combination of headability and corrosion resistance.

It should be noted that there are trade-offs in the selection process because each application should be treated as a unique situation. When considering costs, the best choice is the lowest cost alloy that will provide the properties needed.

Relative corrosion resistance shown on the diagram should only be used as a general guide. For corrosion resistance to specific environments, consult with the alloy supplier. In general, if corrosion resistance is relatively similar, the header should select the alloy with the best combination of headability and cost.

### Typical Uses

Starting at the top of the chart in Figure 20, and referring also to the diagram in Figure 24, Type 430 offers the best formability of all the stainless steels, with slightly less corrosion resistance than Type 304. Its formability is similar to that of low alloy steels which are easy to head. Type 430 has been used for many types of fasteners and bolts.

Type 410 is a hardenable stainless steel with the same tensile strength capability as Type 431 when heat treated. It is less corrosion resistant than Type 431, and has been used most often for sheet metal screws, bolts and fasteners exposed to atmospheric conditions.

TrimRite® stainless, which has been used for self-drilling construction fasteners, has better corrosion resistance than 410, the strength of 420 and corrosion resistance equal to 430.

No. 10 (Type 384) stainless and Custom Flo 302HQ stainless offer excellent headability and corrosion resistance for severely formed parts. No. 10, which has high nickel content, remains nonmagnetic after cold working. The 302HQ alloy, which will be slightly magnetic after cold work, is more readily available than No. 10.

The 302HQ-FM® stainless is a machinable modification of 302HQ that is suitable for both heading and subsequent machining. It has been run in bar form on automatic screw machines to produce parts where thread rolling or cold form tapping operations are critical.

Type 305 stainless has been used for severely formed parts and fasteners made in multiple heading stages. In addition to its good formability, the alloy is also useful for parts that must remain nonmagnetic after cold working. Type 305 stainless resists corrosion by severe atmospheres, nitric acid and foodstuffs.

Type 316 stainless, an easily formed alloy, has superior corrosion resistance and resistance to pitting corrosion in particular. It has been used to make fasteners for the chemical process industries.



Type 304 stainless, which has been used frequently for fasteners with simple head designs, resists severe corrosion and corrodents such as nitric acid. Type 304 modified has been used extensively for construction type fasteners. Composition can be adjusted also to reduce the work hardening rate for fasteners that require more severe forming.

Type 204-Cu should be considered for applications where high strength and good formability are required. The alloy can be considered in fastener applications that currently use Type 304. Two other advantages of Type 204-Cu are that fasteners remain nonmagnetic after cold forming and they are less susceptible to galling than fasteners formed from high nickel 300 series alloys.

Type 431 can be heat treated to higher strength than Type 304; however, Type 431 has slightly inferior corrosion resistance. This alloy possesses the best corrosion resistance of all the hardenable grades and has been used for marine fasteners and aircraft fasteners requiring corrosion resistance and toughness.

Types 321 and 347 are also austenitic stainless steels that can be cold formed. They resist corrosion and heat, and have been used for aircraft fasteners at 800° to 1500°F (427° to 816°C).

Consider using Carpenter 20Cb-3® stainless for fasteners or parts that need resistance to chloride corrosion cracking, hot sulfuric acid and/or many aggressive environments that readily attack Type 316 stainless. This alloy is readily formed and upset.

If more strength is needed than that obtainable in an alloy such as Type 431 stainless, one of three martensitic stainless steels with high tensile strength may be considered. The trade-off with all three is less formability and availability.

Custom 450 stainless is an age hardenable steel which can be used in solution annealed condition. It has the very good corrosion resistance characteristics of Type 304 stainless and good strength characteristics.

Custom 455 stainless is a similar material to Custom 450 stainless, but offers somewhat higher strength levels. It has a hardness capability level of approximately Rc 50.

Custom 630 (17Cr-4Ni) stainless is a precipitation hardenable steel offering high strength and hardness with excellent corrosion resistance. Its strength level is similar to that of Custom 455 stainless.

15Cr-5Ni stainless is a martensitic age-hardenable stainless with similar strength and corrosion resistance to that of Custom 630 stainless, but with improved forgeability and transverse toughness.

15-7PH stainless is a precipitation hardening stainless which is more easily formed in the annealed condition because of its austenitic structure, but capable of high strength via cold working and/or thermal treatment to a martensitic structure.

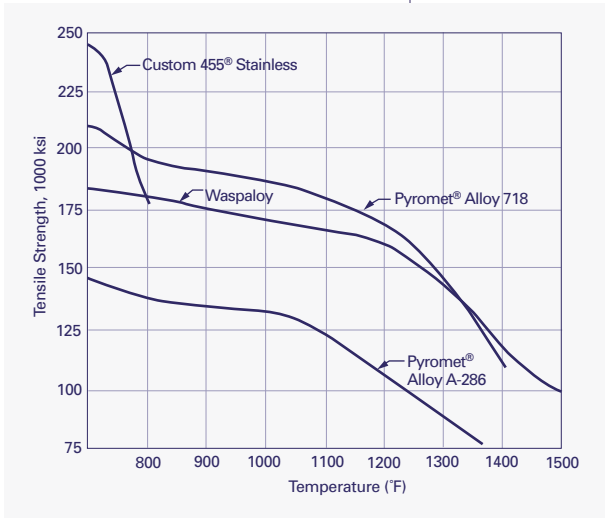

**Fig. 25** Curves for four high temperature alloys illustrate how tensile strength varies with temperature. Heat-resistant alloys such as these exhibit high tensile strength at elevated temperatures.

Type 440C stainless, the most difficult of all stainless alloys to head, obtains its hardenability and high tensile strength through heat treatment. It has been used primarily in applications where balls are headed for stainless bearings.

**High Temperature and Other Specialty Alloy Applications**

More and more cold headers are becoming involved with high temperature and other specialty alloys for fasteners. Initial use of these alloys was for aircraft applications, but today they are being used in many other industries. One example is the automotive industry and its drive to reduce the weight of vehicles.

High strength materials permit the use of smaller bolts without sacrificing strength. Energy exploration with its harsh environments also demands alloys which can withstand high temperatures and possess high levels of strength.

Many of these alloys are quite cold-formable despite their initial high strength levels. Carpenter offers these alloys in their lowest strength form for maximum cold formability in either the overaged or solution-treated condition. Maximum requirements for part integrity and fatigue life can be met with Carpenter's seam-free products.

In heading the precipitation hardening and high temperature alloys, it is necessary to establish a controlled flow pattern in the first deformation to avoid excessive initial hardening. While alloys such as Pyromet® alloy 718 and Waspaloy will work harden in the formed areas to approximately Rc 50 to 56 during final forming, other alloys such as Pyromet alloy A-286 and Custom 455 stainless have been designed for less rapid work hardening. They will harden to only about Rc 36 to 45 in the final forming step.

Warm and hot heading techniques are often used to improve the formability of the high temperature alloys. Aircraft engine bolts have been cold formed from alloys such as Pyromet alloy 718 and Waspaloy. As an alloy with good mechanical properties to 1300°F (704°C), Pyromet alloy 718 has been useful for high temperature fasteners.

In another example, design engineers for a nuclear fusion test reactor chose Pyromet alloy 718 and Pyromet alloy A-286 for high strength, close tolerance fasteners to position and hold down compression plates separating the torroid's field coils.

Successful thread rolling of these large diameter fasteners—1¼" to 2¼" sizes—in the age hardened condition was accomplished by the fastener producer who selected Pyromet alloy 718 for its high strength and non-magnetic properties. Carpenter supplied the alloy in an age-hardened condition with a strength of 200 ksi (1379 MPa). The customer was able

to thread roll the large fasteners (studs with a drive hole in one end) at a hardness of Rc 44 to 46 using modifications to the company's existing equipment and manufacturing methods (Figure 26). In addition to producing the largest fastener size ever thread rolled by a customer using Pyromet alloy 718, the customer also produced spanner nuts from Pyromet alloy A-286 for the fusion reactor. While this is a highly unusual application, it demonstrates the success being achieved in cold working such alloys.

Waspaloy (AISI Type 685) has been used in gas turbine engine parts that require considerable strength and corrosion resistance up to 1600°F (871°C). While more difficult to cold form than Type 316 stainless, Waspaloy can be cold headed. Tensile strength ranges from about 110 to 140 ksi (758 to 965 MPa) depending on the grade and the condition in which it is supplied.

Similar opportunities exist with other high temperature alloys and precipitation hardening stainless grades, such as Carpenter 15-7PH, Carpenter PH 13-8 Mo alloy (a trademark of Armco, Inc.), Custom 630 (17Cr-4Ni) and Pyromet alloy A-286. Pyromet alloy A-286, for example, has been used for bolts to hold superchargers on engines and to fasten together small instrumentation packages for energy exploration that can withstand harsher environments and elevated temperatures.

Custom 630 and PH 13-8 Mo alloys both have good fabricating characteristics and can be age-hardened by a single low temperature treatment. PH 13-8 Mo alloy, compared to other ferrous-base materials, offers a high level of useful mechanical properties under severe environmental conditions. Pyromet alloy 41 possesses high strength in the 1200° to 1800°F (649° to 982°C) temperature range. It has been designed for severely stressed high temperature applications.

Another alloy, Pyromet alloy 882 (AISI Type H-11), has solved many cold working applications where extra toughness was required at the sacrifice of some wear resistance. This steel has also been used as aircraft structural material for critical components in aircraft and missiles. It can be used at very high strength levels, some in excess of 260 ksi (1793 MPa).

Of all the materials in this category, NiCu alloy 400 is easiest to form. Its headability relative to other alloys can be seen in Figure 24. Its analysis and strength properties are shown in Figures 20 and 21. NiCu alloy 400, used at temperatures up to 800°F (427°C), has excellent corrosion resistance to seawater, and is virtually immune to chloride stress corrosion cracking. Its very low work hardening rate makes it easy to form. The material has been used extensively for rivets.

### Classification Systems

Headers sometimes may be misled by terms such as “stainless fastener” or “high strength fastener.” Orders which specify these broad terms tend

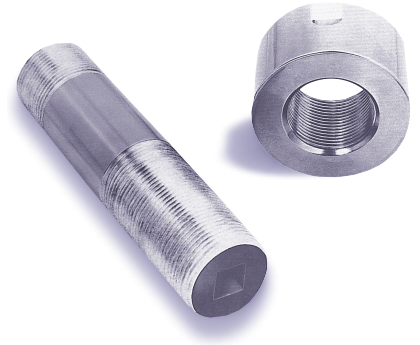

**Fig. 26** These large fasteners that were produced from Pyromet® alloy 718 exemplify the formability of high temperature alloys.

Stainless Steels							
UNS	Producer Designation	AISI	ASTM	ASME	AMS	SAE	Military/Federal
S43000	430	Type 430	A493, 580		5627	J-405	QQ-S-763 QQ-W-423 Std. 66
S41000	410	Type 410	A193,194, 493, 580	SA 194	5613	J-405 J-412	QQ-S-763 QQ-W-423
S42010	TrimRite® Alloy						
S43100	431	Type 431	A493				
S38400	No.10	Type 384	A493				
S30430	302HQ		A493				
S30500	305	Type 305	A313,368, 478, 492, 493, 580	SA 193, 194, 320	5685, 5686	J-405	QQ-S-763 QQ-W-423
S31600	316	Type 316	Numerous	SA 193,194, 320, 403	5648, 5690 5691	J-405	QQ-S-763 QQ-W-423
S30400	304 304 Modified 304 Forming Quality	Type 304	A493		5639	J-405	
S20430	204-Cu		A313				
N08020	20Cb-3® Alloy		B471, 473, 475				
S45000	Custom 450® Alloy		A564		5763		
S17400	Custom 630		A564	SA 564	5643		
S45500	Custom 455® Alloy		A313, 564	SA 564	5617, 5672		
S44004	440C	Type 440-C	A493, 580		5618, 5630	J-405	QQ-S-763
High Temperature/Specialty Alloys							
UNS	Producer Designation	AISI	ASTM	ASME	AMS	SAE	Military/Federal
N07718	718				5662		
S66286	A-286				5731, 5732, 5734, 5735, 5736, 5737,		
N07001	Waspaloy				5708		
N04400	Ni-Cu 400						QQ-N-281

to be ambiguous since there are many alloys to choose from. Each offers a specific set of properties in the finished product.

Disappointment most likely awaits the header who tries to substitute one stainless or high temperature alloy for another in an attempt to gain lower raw material costs, faster production or other advantages. If the fasteners must be non-magnetic, for example, neither Type 430 nor Type 410 stainless steels can be used despite their excellent formability.

Much effort has been devoted to making the alloy choice easier through increased specification standards. In the broad sense, the Unified Numbering System (UNS) represents an attempt to establish a universal method for classifying alloys.

Such a system is necessary, for example, when you examine Figure 27 and see how many specifications cover one alloy. This table lists the basic headable stainless steels and high temperature alloys, and shows how each grade is specified according to several classification systems.

In a further attempt at standardization, the American Society of Testing and Materials (ASTM) has developed specifications for stainless steel. F593 is for bolts, hex cap screws and studs; F594 is for nuts; and F738 for metric bolts, screws and studs.

Numerous stainless grades are included in the ASTM specifications. While these ASTM fastener standards do not include all headable stainless alloys, they do provide broad coverage and include stainless grades used to produce machined fasteners.

Specifications such as F593, F594 and F738 are designed to place general limits on stainless alloys, classifying them by the percentage and types of elements included in each alloy's composition. Specifications, however, by their very nature are not always the last word.

**Fig. 27** Classification systems for popular stainless steels and high temperature/specialty alloys.

For example, seven headable stainless grades—Types 430, 410, No. 10, 305, 316, 304 and 440C—meet the Society of Automotive Engineers (SAE) specifications for cold finished annealed wire. Those specifications are insufficient to guide selection when considering the obviously wide gulf between the corrosion resistance of Type 410 and Type 316 stainless. Selection of the proper alloy must depend upon the corrosion resistance and strength level demanded by the particular application.

When considering a stainless steel for a forming application, the user should always refer to ASTM specification A493 for wire feedstock. For the header, it is the most useful guide for specifying wire because it gives each alloy's chemical composition and mechanical properties. Assuring the composition and properties defined is the natural responsibility of the wire supplier.

### **Summary**

If no material specifications are provided, the heading shop or department can select the proper stainless steel or high temperature alloy for a job by considering the following factors in the order presented:

1. Determine the required corrosion resistance.
2. Determine the required strength, factoring in the effects of cold working and heat treatment.
3. After narrowing the choice with the preceding criteria, determine which alloy has the best headability.
4. Make certain the alloy you want is readily available.
5. Don't overlook the part or fastener complexity, or the importance of the heading wire coating.

Use the diagram in Figure 24 to determine the relative corrosion resistance and headability of candidate alloys. Refer also to the chart in Figures 20 and 21 to evaluate the easiest-to-most-difficult alloys to head, and assess their relative strengths. Contact Carpenter for assistance in selecting the right alloy, or modifying one for optimum job performance.

Finally, do check industry specifications that apply and, by all means, refer to the important ASTM specifications A493 for wire feedstock.

### **Wire Quality and Selection**

Even with proper grade selection, the quality of a finished part can only be as good as the raw material from which it was produced.

Like the term “stainless fastener,” the term “stainless wire” is also ambiguous. Carpenter, for example, can supply headers with an almost infinite variety of wire stock in numerous conditions and with various coatings.

Standard Size Tolerances for Cold Drawn Heading Wire	
Size Range	Tolerance
Up to 0.312" diameter	±0.001"
0.312"–0.499" diameter	±0.0015"
0.500" diameter	±0.002"

Note: Half-standard tolerances may be ordered.

Fig. 28

Standard Rod Tolerances	
Size Range	Tolerance
0.221"–0.4375"	±0.006"
0.453"–0.625"	±0.007"
0.641"–0.875"	±0.008"
0.891"–1.000"	±0.009"
1.000"–1.250"	±0.010"

Fig. 29

### Product Forms

Carpenter manufactures three basic wire product forms in addition to specially finished wire or rod for special applications. The three basic forms include:

1. **Annealed and Cold Drawn to Finish Heading Wire**
2. **Cold Drawn and Annealed at Finish Heading Wire**
3. **Hot Rolled and Annealed at Finish Rod.**

The following is a discussion of the advantages or disadvantages of each.

**Annealed and Cold Drawn to Finish Heading Wire** is raw material in the finished condition. It is available in all sizes up to about 1.00" (25.4 mm) in diameter. See the following table for specific size tolerances (Figure 28). Wire in this condition offers substantial surface integrity and the widest range of mill coatings. This product typically does not require additional sizing prior to entering the header.

**Cold Drawn and Annealed at Finish Heading Wire** supplied cold reduced, annealed and coated. It offers the lowest mechanical properties and is suitable for redraw or heading. This product should be sized prior to entering the header. Cold drawn, annealed product is available in all sizes up to about 1.00" (25.4 mm) in diameter. Tolerances are double those available on annealed and cold drawn wire.

STARR (Stainless Annealed Ready for Redraw) WIRE® is a modification of the basic cold drawn and annealed at finish form. Its manufacturing sequence typically includes additional operations to enhance surface quality. It is available in only a few stainless grades and is typically supplied with a cross sectional area about 5 percent over the cross sectional area of the finish drawn product.

**Hot Rolled and Annealed at Finish Rod** is the least finished condition and must be sized prior to entering the header. It is supplied annealed, descaled and coated. Of the three wire forms, rod has the roughest surface and the widest tolerances. Rod is available in a size range from about 7/32" to 1 1/4" diameter. Tolerances may be as great as ±0.010" with a maximum of 0.015" out of round in the larger diameters (Figure 29).

To reduce wire inventories and the number of wire sizes purchased, some headers draw wire or rod in front of the header with obvious savings.

**Seam Free Wire**, in addition to these standard products, offers the ultimate in product reliability when required. Seam free wire—from which the hot mill surface has been mechanically removed—is available. This product is generally polished, annealed and cold drawn subsequent to the surface removal process.

See the following section, "Which Wire Product Form?," for more detailed information about the advantages and disadvantages of the Hot Rolled and Annealed at finish Wire product form.

### Which Wire Product Form?

In an effort to reduce wire inventories and the number of wire sizes purchased, some headers draw semi-finished wire or hot rod in front of the header with obvious savings. However, semi-finished wire also has some disadvantages. It is available in a limited number of grades and sizes. In addition, its properties may not be suitable for all applications. A case in point is too much draw down, which results in an unacceptable work hardening, makes forming difficult, if not impossible.

While hot rod is the lowest-cost wire stock, this may or may not be an advantage. Many fabricators report that hot rod necessitates the addition of more in-house capabilities. When redrawing hot rod, scrap losses generally increase and this presents overall quality control problems that often negate initial raw material savings.

The best alternative for most headers is the use of wire which has been cold finished, if supplied by the producer ready to go into the header, or requiring only a slight draw prior to fabrication. A key benefit to users of cold finished wire is that the wire producer assumes the responsibility, not only for chemistry, but also for mechanical properties and size tolerances. When redrawing hot rod in front of the header, the fabricator assumes these responsibilities.

Finally, another concern expressed by headers is inconsistent raw material. It cannot be stressed enough that the heading process is made much easier with raw material that is consistent and uniform from lot to lot. Since specifications for standard grades permit wide ranges of alloy content in the analyses, it is important to select a wire producer that melts to narrower ranges, specifically for cold heading applications. In this way, the header is assured that each lot of material will have the same heading characteristics.

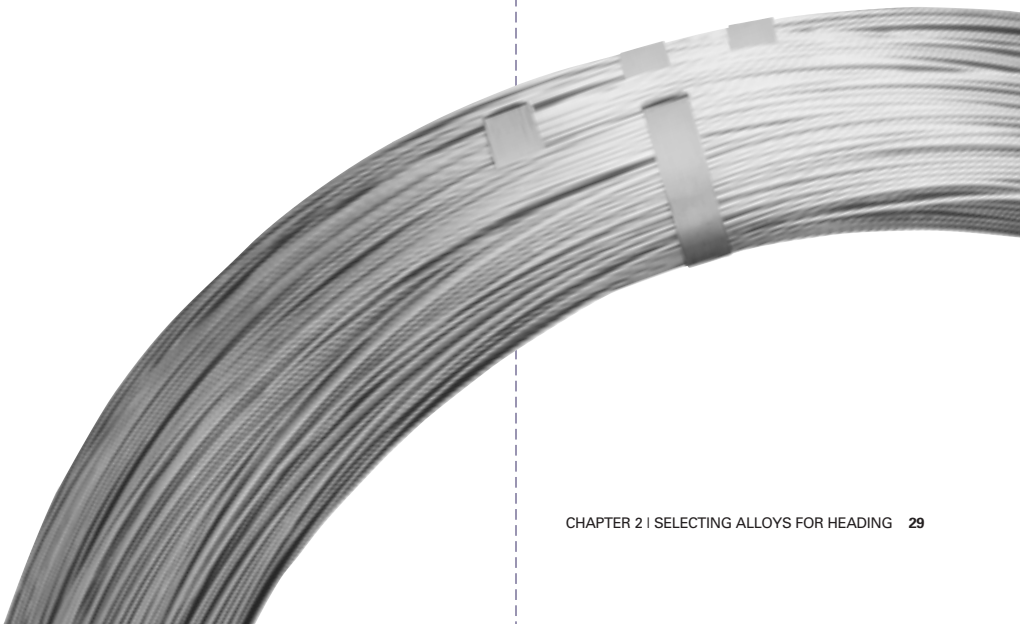

### **Cold Finished Stainless Wire Offers Numerous Advantages**

The trend toward reduced inventories, increasingly complex design configurations and financial concern in the heading industry necessitates the consideration of cold finished wire for most stainless steel applications and virtually all high temperature alloy cold formed components. Cold finished wire is ready for the header when it comes through the door. This benefits both the experienced and inexperienced headers. Fabricators with expertise in heading the tougher alloys can benefit from cold finished wire because it allows them to concentrate only on the production of finished parts and not redrawing wire. Fabricators with little stainless steel heading experience have found that cold finished wire helps to make a smoother transition from carbon steels to stainless steels.

The advantages of cold finished wire are numerous:

1. **Tolerances**—Cold finished wire has the tightest tolerance of all forms. Hot rod tolerance in the larger diameters is  $\pm 0.009$ " compared to only  $\pm 0.002$ " for annealed cold finished wire.
2. **Processing**—The manufacturing sequence for cold finished wire tends to eliminate metallurgically unsound wire based mainly on the number of extra inspections. Uniform, consistent lot-to-lot properties are achievable with premium melting, repeated working and annealing, relatively heavy cold reduction (25 to 30 percent) and closely controlled thermal cycles. Cold finished wire is supplied in its most cold formable state.
3. **Quality Level**—Permissible levels for laps, seams, nonconcentricity or overfills are obviously less for cold finished wire compared to hot rod or semi-finished product. Better quality translates into less scrap. One heading firm reported that scrap losses increased from one percent with cold finished wire to three percent for less finished wire.
4. **Controllable Properties**—Cold finished wire has narrow standard or custom tensile strength maximums. Surface finishes are uniform; proper coatings complement cold finished wire's predictable properties in the finished part.
5. **Better Coils**—Cold drawing provides a better coil package.
6. **Availability**—Cold finished wire is more readily available than hot rod or semi-finished wire through general or custom warehouse inventory, and standard or custom mill ordering. In addition to being stocked in the most popular headable stainless steels and high temperature alloys, cold finished wire is accessible in any stainless alloy specified for heading. STARR WIRE®, or semifinished wire, by comparison, is available in only four grades. The minimum poundage order is less for cold finished wire than other forms.





## Chapter 3

# Coatings and Lubricants

### Introduction

Proper lubrication is extremely important to the successful heading of stainless steels, high temperature alloys and other specialty metals. Whether it's the low level upsetting of an easily headable grade such as Type 410, or heavy extrusion (greater than a 20 percent reduction in area) of a high temperature alloy such as Pyromet alloy A-286, a basic knowledge of coatings and lubricants helps prevent subsequent fabrication difficulties like galling, die seizing or tooling failure. In this chapter coatings are defined as materials applied to the wire at the mill; lubricants are defined as materials applied by the fabricator during heading.

During the last several years, many improvements have occurred in headable stainless steels and high temperature alloys. Tighter analysis control, special additions and improved melting and manufacturing methods employed by Carpenter are responsible for the improved headability of stainless steels. At the same time, equipment, such as complex multi-station headers, has increased the ability of wire and rod processors to head even the toughest alloys. Similar advances have occurred with coatings and lubricants. Carpenter offers perhaps the widest variety of standard and custom coatings in the steel industry. Carpenter has developed a logical alpha-numeric coding system to identify them. This system is covered later in this chapter.

Carpenter's coating capabilities complement the production of uniform, consistent stainless steel cold heading wire in the following forms: annealed cold finished heading wire, cold finished annealed heading wire, STARR WIRE® (Stainless Annealed Ready for Redraw) and hot rod. When you consider the number of headable stainless grades, their available product forms and the variety of coatings offered, it's obvious that many combinations are possible to match cold forming applications.

### What are Coatings?

Coatings are substances applied to the wire by electroplating, dipping, or drawing at the mill. Electroplated copper is the most popular Carpenter coating, and the most versatile as it can be used in combination with all other coatings. The variety of available combinations will provide lubrication for most forming operations, including the most severe upsets and/or extrusions.

Lime and precoat are dried particulate coatings which act as carriers for drawing lubricants and as boundary lubricants in forming operations. These particles can be affected by moisture or be removed by simple handling. For maximum coating adherence, it is recommended that the wire be given a light draft in drawing soap to seal and protect these coatings.

Ecolube® II alloy, Moly overcoat, and Carpenter's new KnightCote™ are a special type of dry particulate coatings known as layer lattice compounds. The ability of these particles to shear and slide under tremendous loads, and at elevated temperatures, provides a mechanism for lubrication during the most difficult forming applications. These coatings are put on wire stocks by special proprietary application methods. Drawing after coating, either with or without added soap, will also improve the adherence of these layer lattice compounds.

The most common drawing compounds for wire products are stearate type soaps. Molybdenum disulfide containing soaps can be specified for more severe forming applications. Oils and greases can be used where a lighter residual coating is required. Wire coated with Ecolube II alloy, Moly overcoat, and Carpenter's new KnightCote can be drawn without added soap or grease. In special applications, other drawing compounds may be able to be used, but customers should check with their Carpenter representative to determine the availability and costs for these products.

### **Why Use Coatings?**

The heading process includes upsetting, extruding and forming, or a combination of these. The process requires great pressure that generates high temperatures because of tremendous internal and external friction. Without sufficient lubrication, the heading process would run metal against metal, literally welding the wire to the die. Excessive die wear, galling or seizing may occur. Heavy, or combination, coatings are required for severe heading operations because the greater pressure means more friction, higher heat and, therefore, more rapid breakdown of the coating.

Coatings simply act to reduce friction in the heading operation by providing a film that prevents metal-to-metal contact. Since stainless steels and high temperature alloys are generally more difficult to form than carbon or lesser alloyed metals, coatings are a key factor in the fabrication process. A low carbon steel, for example, may require only a light machine oil application during heading, while stainless steels need more durable coatings, such as copper, Ecolube II alloy, or a precoat and soap.

### **Which Is the Right Coating?**

Choice of the proper coating is heavily influenced by the specific application. However, there are general considerations. The type of coating required depends largely on the alloy being formed, the degree of cold work needed, the temperature generated by the heading process, and the complexity of the part being formed. Additional factors influencing coating selection include availability and cost, compatibility with other mill coatings or fabricator lubricants, and the ease of coating removal from the finished parts.

As mentioned earlier, for many years the most effective coating for stainless steel heading wire has been an electrolytically plated copper layer plus lime and soap drawn on during the final light draft made in finishing the wire. Today, however, coatings such as Carpenter's Ecolube II alloy are becoming increasingly popular because they eliminate the problems associated with disposal of cleaning acids containing metal ions. A key point to remember is that Carpenter, as a leading producer of stainless heading wire and rod and a variety of coatings, is totally equipped to help customers with coatings selection, as well as all other aspects of cold heading operations.

### Carpenter's Coating System Helps Pinpoint Proper Formulation

Coating classes are determined by selecting a coating option designated by a letter and a drawing option designated by a number (Figure 30).

This is typically referred to as Carpenter's Alpha-Numeric Coating Classification System. The coating and drawing options are as follows:

Alpha-Numeric Coating Classification System	
Must choose one coating option and one drawing option.	
Coating Options (Alpha)	Drawing Options (Numeric)
A Uncoated	1 Undrawn (Annealed at finish)
B Lime	2 Drawn in Soap
C Precoat	3 Drawn in Grease
F Ecolube® II Alloy	4 Drawn in Molybdenum Disulfide-Bearing Soap
H Copper + Lime	5 Drawn Without Soap or Grease (Only Coatings F, N, O, R, S)
K Copper	6 Special
L Copper + Precoat	
N Copper + Moly Overcoat	
O Copper + Ecolube II Alloy	
P Special	
R KnightCote™	
S Copper + KnightCote	

**Fig. 30** When copper plating is ordered on wire up to 0.327" diameter, appropriate alloys will be strand plated. Larger diameters and all sizes of high-strength alloys such as Waspaloy alloy, Pyromet® 718 alloy, and Custom 630 stainless will be batch plated. Copper thickness will be about 100 micro inches (0.0001") on all wire 0.100" diameter and larger. The thickness on wire <0.100" diameter will be about 75 micro inches (0.000075"). Other copper thicknesses are available upon request.

### **Using Lubricants During Heading**

The standard cold heading lubricant is lubricating oil with extreme pressure additives such as sulfur, chlorine or neutral animal fat. It is most often a combination of sulfurized fat and a chlorinated additive and is available from a number of suppliers. Lubrication during heading, of course, is vital in reducing die wear, promoting good finishes, and eliminating galling, seizing and scratching by preventing pick-ups on the die. To do this, lubricating oil flows over each of the three basic heading operations, beginning with wire or rod fed through the straightener and cut-off knife, continuing through upsetting, extruding and/or forming operations, and ending with the final forming operation.

### **How the Lubricant Works**

As the lubricating oil flows through the cold heading sequence, the sulfur and chlorine components of the lubricant form ferrous sulfides and chlorides that prevent welding and act the same as a solid lubricant. A continuous film is being formed and destroyed as the metal is in the process of moving and forming. The fat component in the lubricating oil adds lubricity to the mineral oils present.

The proper viscosity or thickness of the lubricant depends on temperatures generated by the cold forming sequence; naturally higher temperatures require higher viscosities. A good rule of thumb is to begin with a standard lubricant at full strength, and make adjustments up or down. A small, simple component may allow cutting back full strength lubricant by adding mineral oil. A more complex part may require using a heavier grade of lubricant.

### **Cleaning Processes for Headed Parts**

Finishing operations require that cold formed stainless parts be cleaned to remove coatings and lubricants. The specific method of cleaning depends upon the type of coating or lubricant being removed. Here are some specific removal methods. It should be kept in mind, however, that these cleaning operations do not replace passivation. See page 37 for passivation procedure.

### **Lubricants, Soap, Lime and Precoat Removal**

Detergent-based cleaners are generally adequate for removing most soluble soaps, greases and oil residues from headed parts. The chemical supplier should recommend the optimum operating temperature and concentration for the cleaning solution. Agitation will usually speed up the cleaning process and will help loosen particulate matter such lime residues. Rinsing of the cleaned parts using pressure sprays, solution agitation, or rapid part movement assists in removing the last traces of dirt and cleaner residues.



### **Ecolube® II Alloy, Molykote®\* and KnightCote™ Removal**

These coatings can also be removed from fabricated parts using detergent or alkaline cleaner formulations. Surfactant and dispersant additives in the cleaner will help dislodge the fine particulate material comprising the coating, and keep it in solution. The chemical supplier's recommendations should be followed regarding bath type, operating temperature and solution concentration. Solution agitation, moving of the parts by tumbling or stirring, ultrasonic energy, and high pressure spray rinsing will assist in dislodging these coatings. The coating particulate may be removed from the cleaning solution by filtering, centrifuging, or by allowing the solids to settle and decanting the clean liquid.

### **Copper Electroplate Removal**

**Nitric Acid:** Copper can be readily removed from fabricated parts by immersing them into a solution of nitric acid at 30 percent concentration or higher. The reaction proceeds quickly at room temperature, and more rapidly at temperatures of 140° to 180°F (60° to 82°C). Solution agitation and part motion will aid in complete removal of the copper coating.

**Sulfuric Acid:** Hot concentrated sulfuric acid will dissolve copper. This acid, however, also attacks many steel grades and should be used only in very special cases. Formulations of stabilized peroxide in sulfuric acid are also used to remove copper. These products are commercially available from several suppliers. Compatibility of these chemicals with your existing tanks, racks, baskets, other materials and processes must be established.

**Other Methods:** Several commercially available formulations have been developed to strip copper and similar metals from various base metals. These products are often neutral to slightly alkaline, relatively safe to handle, and can often be disposed of by standard treatment facilities. Customers should check with their chemical supplier for compatibility of these products with various metals; methods and precautions to be observed when using these products; and operating conditions and bath controls.

**Combination Coatings:** A two-step process can be used to remove layered or combinations of different coatings over copper. First, a detergent or alkaline cleaner will remove the lubes, soaps, precoat or KnightCote, followed by stripping of the copper as a second step.

### **Passivating Stainless Steels**

The corrosion resistance of stainless steels is due to a very thin, invisible oxide film that completely covers the surface of the parts and prevents corrosion from taking place. A freshly formed, polished or pickled part will acquire this film rather quickly through contact with the atmosphere. Some fabricated components, however, may be contaminated with small

particles of foreign matter, which should be removed to impart full stainless properties. The passivation process accomplishes this. The primary purpose of the passivating treatment is to remove surface contamination, usually iron, so that the optimum corrosion resistance of the stainless steel will be maintained.

The general procedure for passivating is to immerse parts in a warm solution of nitric acid or nitric acid plus oxidizing salts for about 30 minutes. Specific details are shown in Figure 31.

Passivation should be preceded by one of the cleaning processes on pages 35-36, followed by a thorough water rinse. The addition of sodium dichromate or use of the 50 percent nitric acid increases the “passivating potential” of the bath so that undesirable local attack is less likely. Note that the passivation techniques shown in Figure 31 do not include the free machining grades, which require different procedures.

### Other Important Passivation Considerations

Carpenter recommends the following important considerations during the passivation process:

1. A good passivating solution is required to prevent local attack. Tap water is usually adequate, though a high chloride content (greater than several hundred ppm) could cause problems. Nitric acid content must be periodically checked.
2. When high production rates pass through the passivating bath, maintain a definite schedule for replacing the bath to avoid contamination.
3. Maintain the bath within a specific temperature range. A room temperature bath has a lower “passivating potential” than a warm bath and, therefore, is more likely to cause local attack.
4. It is good practice to passivate only one grade at a time. Attack can occur in the bath with parts that are improperly heat treated. High-carbon, high-chromium grades must be hardened to render them corrosion resistant.

Passivating the Stainless Steels	
Grades	Passivation
<ul style="list-style-type: none"> <li>• Chromium-Nickel Grades (300 Series)</li> <li>• Grades with 17% Chromium or more (except 440 Series)</li> </ul>	20% by vol. nitric acid at 120/140°F (49/60°C) for 30 minutes
<ul style="list-style-type: none"> <li>• Straight Chromium Grades (12-14% Chromium)</li> <li>• High Carbon-High Chromium Grades (440 Series)</li> <li>• Precipitation Hardening Stainless</li> </ul>	20% by vol. nitric acid + 3 oz. per gallon (22 g/liter) sodium dichromate at 120/140°F (49/60°C) for 30 minutes OR 50% by vol. nitric acid at 120/140°F (49/60°C) for 30 minutes

**Fig. 31** Passivation methods for the different types of stainless steels are shown in this table. The table does not cover free machining stainless grades.

## Chapter 4

# Tooling for Heading

### Introduction

The success of any heading operation depends to a large extent on the performance of the header tooling. Properly engineered tooling should provide trouble-free operation, while tooling related deficiencies often result in poor part quality, lost productivity and excessive costs. Such issues become even more critical in the case of difficult to head materials (such as stainless steel) due to the increased demands placed upon the tooling.

Four areas of significant heading tool usage are defined within the industry: die inserts, recessed punches, thread rolls, and casings. These are the most popular tooling categories and account for more than 90 percent of all heading tools utilized.

Tool performance is determined by the many variables that are inherent in the design, construction, and maintenance of the components used in each of these tooling categories. Detailed discussion covering each of these areas is beyond the scope of this article. However, the following will highlight the proper selection and treatment of tooling materials as well as some basic considerations involved with the construction of die components.

### Selection of Tooling Materials

Today the tooling engineer can select from a very wide range of tool materials. The list might include conventional tool steels, ultra-high strength tool steels, advanced P/M tool steels, or cemented tungsten carbide. The selection process requires an understanding of which tool material properties are most critical. This can often be determined from the type of failure mode exhibited by the tooling used in a given application.

In the case of heading tools, wear resistance and toughness are usually considered to be the primary selection criteria. Tools that fail due to abrasion or galling indicate a need for additional wear resistance. Conversely, tools which fail due to chipping, micro-chipping, or breakage indicate a need for toughness. Other properties which are critical in heading applications include hardness, compressive strength (resistance to deformation), and fatigue strength (resistance to cyclical stresses).

To help in the selection process, Carpenter has developed a special chart (Figure 32) that plots relative wear resistance and toughness of representative tool steels and carbide. The chart references the relative positions different tooling materials, making it easy to tell at a glance what combination of wear resistance/hardness and toughness can be expected



from a given material. The final choice for a particular application can then be made by evaluating more specific properties offered by the material of interest.

The tooling materials chart clearly shows the inverse relationship that exists between wear resistance and toughness. In general, optimum tool performance can be obtained by using the material that offers the highest wear resistance while still maintaining the minimum level of toughness required by the given application. In the same manner, it is often possible to upgrade to a more wear resistant material provided that proper steps are taken to minimize the impact and shock encountered by the tooling. This is clearly the case with cemented carbide tooling which requires carefully engineered tool design along with highly accurate and rigid machine setup due to the inherently low toughness of carbide.

Fig. 32

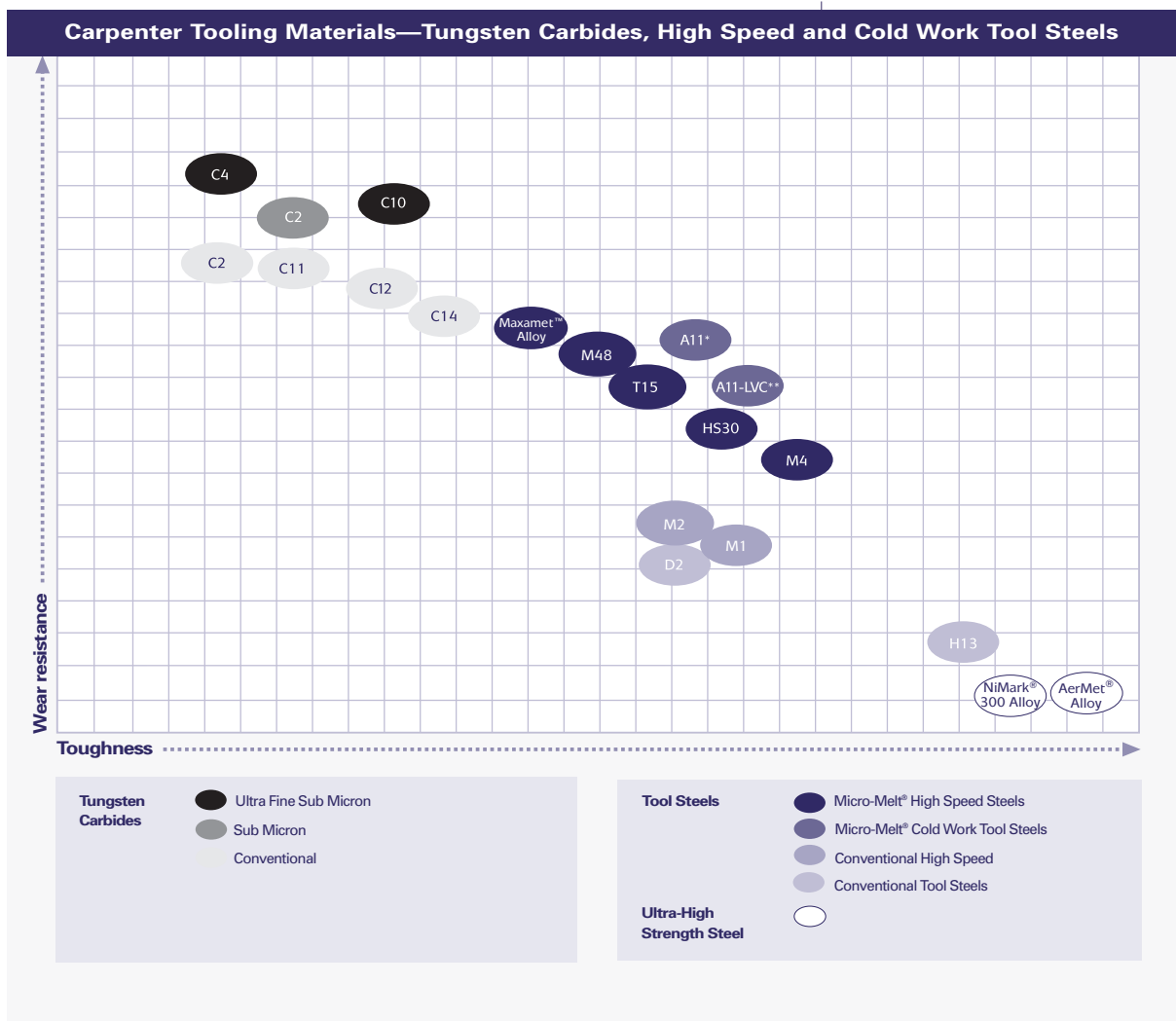

### Carpenter Advanced Tooling Materials

The advanced tooling materials offered by Carpenter provide a unique combination of wear and toughness properties, and can often be used as an easy upgrade over the more conventional tool steels (Figures 33 and 34). This type of upgrading can be an effective means of dealing with some of the tooling issues often associated with the heading of difficult materials. More detailed descriptions covering the most common advanced tooling materials are shown in the following section. Please contact Carpenter if further information is needed on these or other tool materials.

Fig. 33

Wear Resistant Grades		
<p><b>Micro-Melt® M4 Alloy</b></p> <p>(AISI Type M4)</p> <p>(UNS T11304)</p> <p>1.35 C, 0.30 Mn, 0.30 Si, 0.06 S, 4.50 Cr, 4.50 Mo, 4.00 V, 5.50 W, Bal. Fe</p> <p>(Nominal analysis)</p> <p>A molybdenum/tungsten-bearing powder high-speed tool steel with high carbon and vanadium contents. This grade provides very high wear resistance along with high strength.</p>	<p><b>Micro-Melt® A11 Alloy</b></p> <p>(AISI A11)</p> <p>(Equivalent in hardness, wear resistance and heat treating response to CPM 10V® alloy. CPM 10V is a registered trademark of Crucible Materials Corporation.)</p> <p>2.40/2.50 C, 0.35/0.60 Mn, 0.75/1.10 Si, 4.75/5.75 Cr, 1.10/1.50 Mo, 9.25/10.25 V, 0.05/0.09 S, Bal. Fe</p> <p>(Single figures are maximums)</p> <p>A high-vanadium, powder metal cold work tool steel with wear resistance superior to most other tool steels, and possessing good strength and toughness characteristics.</p>	<p><b>Micro-Melt® T15 Alloy</b></p> <p>(AISI Type T15)</p> <p>(UNS T12015)</p> <p>1.50 C, 0.06 S, 4.75 Cr, 5.0 V, 13.0 W, 5.0 Co, Bal. Fe</p> <p>(Nominal analysis)</p> <p>A high-carbon tungsten/cobalt vanadium powder high-speed tool steel having excellent abrasion resistance and red hardness.</p>

Fig. 34

Fracture Resistant Grades	
<p><b>AerMet®-for-Tooling Alloy</b></p> <p>(U.S. Patent Nos. 5,087,415 and 5,268,044)</p> <p>(UNS K92580)</p> <p>0.23 C, 3.00 Cr, 11.10 Ni, 1.20 Mo, 13.40 Co, Bal. Fe</p> <p>(Nominal analysis)</p> <p>A double-vacuum melted iron-cobalt-nickel alloy possessing high hardness and strength combined with exceptional ductility and toughness. Designed for components which require a combination of HRC 53/55 hardness with the highest toughness available.</p>	<p><b>NiMark® Alloy 300</b></p> <p>0.03 C, 0.10 Mn, 0.10 Si, 0.01 P, 0.01 S, 18.00/19.00 Ni, 4.70/5.10 Mo, 8.0/9.50 Co, 0.50/0.80 Ti, 0.05/0.15 Al, 0.030 Zr, 0.003 B, 0.05 Ca, Bal. Fe</p> <p>(Single figures are maximums)</p> <p>This low-carbon, nickel maraging alloy attains yield strengths over 270 ksi (1862 MPa) through simple low temperature heat treatment. Excellent notch ductility.</p>

## Application Guidelines

Although many variables are involved in the selection of tool materials, it is often the case that certain materials tend to be the preferred choice in specific applications. The following section provides a list of both the standard and advanced tooling materials that have been commonly used in the main tooling categories (Figures 35, 36, 37 and 38).

Die Inserts	
Advanced Tooling Materials	Standard Grades
Micro-Melt® M4 Alloy	Speed Star® Alloy (AISI Type M2) No. 610® Alloy (AISI Type D2)
Micro-Melt A11 Alloy	
Micro-Melt T15 Alloy	

Fig. 35

Recessed Punches	
Advanced Tooling Materials	Standard Grades
Micro-Melt M4 Alloy	Star-Max® Alloy (AISI Type M1)
Micro-Melt T15 Alloy	Speed Star® Alloy (AISI Type M2)

Fig. 36

Thread Rolls	
Advanced Tooling Materials	Standard Grades
Micro-Melt M4 Alloy	No. 610 Alloy (AISI Type D2)
Micro-Melt A11 Alloy	Speed Star Alloy (AISI Type M2)
Micro-Melt T15 Alloy	

Fig. 37

Casings	
Advanced Tooling Materials	Standard Grades
AerMet®-for-Tooling Alloy	No. 883® Alloy (AISI Type H13)
NiMark® 300 Alloy	

Fig. 38

### Heat Treatment of Header Tooling

Few toolmakers would disagree with the fact that tool steels must be heat treated correctly if tooling is to have any chance of performing at an optimum level. This is especially true in the case of the advanced tooling materials which tend to be less forgiving in nature due to their high alloy content. In the same manner, it is often possible to fine-tune tooling properties for a particular application through careful selection of heat treatment parameters. It is highly recommended that the reader contact Carpenter, or consult with a qualified heat treat professional if further assistance is needed in this area.

### Thin Film Coating

Another method of improving tool performance that has become very common involves the use of advanced, thin film coatings on the surface of the tooling. Although many coating processes are currently available, the most frequently used are the PVD coatings such as TiN, TiCN, and TiAlN. These hard coatings are applied using sophisticated technology and can be used effectively on a broad range of substrate materials. Although a bit of trial and error is needed to find the optimum combination of coating and tool material for a given application, the improvement in tool life can often be significant when coatings are effectively utilized. Please consult a qualified coating source for more information in this area.

### Cold Heading Die Stations and Die Construction

#### Selecting the Right Type of Cold Heading Die

There are many types of dies, steels and die construction techniques used in cold heading operations today. The most popular are insert dies. Generally, the insert die is preferred for long runs, for extremely heavy upsets, or for applications where die configuration is complex (Figure 39). Solid die construction is sometimes used for short runs because of its lower initial cost.

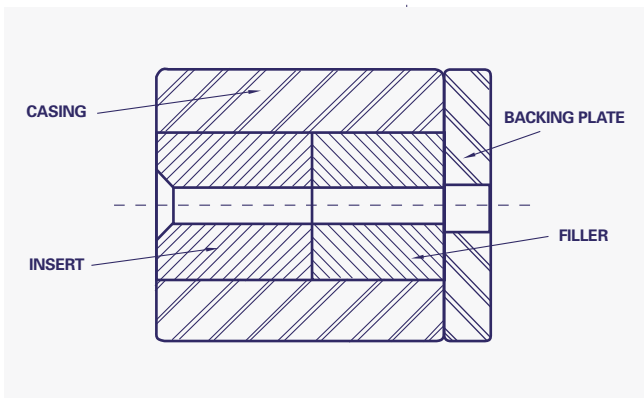

Fig. 39

#### Insert Dies

The major advantages of the insert die are its flexibility and the savings offered in die repair costs and lower tool inventory.

Often, it is possible to use the same grip or shouldered insert for many different length threaded bolts. The extruding insert can be used for heading bolts that have different grip lengths within the same bolt diameter. The header point can be used in conjunction with any combination of thread and grip length as long as the bolt diameter is the same.

If the first insert should fail, it is a simple matter to eject and replace it. The original extruding and pointing inserts and casing can still be utilized. This simple operation saves many hours in die repairing.

### Insert Die Construction

**Casing:** The relationship between the casing outside diameter, or shroud (Figure 40), with the inside diameter is very critical. This relationship is frequently abused. Naturally, the geometry of the part has direct bearing on this relationship. As a general rule, the outside diameter should equal  $2\frac{1}{2}$  times the inside diameter (O.D. =  $2\frac{1}{2}$  x I.D.).

### Installation

The two most widely used methods are the press and shrink methods. The procedure for each follows:

**Press method:** A good rule of thumb is that the insert O.D. is 0.003" to 0.004" larger than the I.D. of the casing. The insert has a taper of 0.001" per inch of length. It is pressed into the rear of the casing with the small diameter of the insert leading. A word of caution—loss of press (elasticity of casing) will result in insert failures due to lack of support.

**Shrink method:** Generally it is desirable that the insert O.D. is 0.0015" to 0.002" larger than the casing I.D. The casing is then heated to 500°F and the I.D. expands approximately 0.002" to 0.0025". The insert is then frozen to approximately -120°F, which results in a shrinkage of approximately 0.002" to 0.003" in the insert's O.D. Next, the insert is installed in the casing and the assembly returned to room temperature (Figure 41).

### Die Design for Heavy Upsets

Insert dies allow the use of the more highly alloyed through-hardening tool steels than solid dies. The casing is designed to absorb the shock while the insert provides high wear characteristics. Experience indicates that through-hardening steels are not suitable for solid dies.

In some cases where unusually heavy upsets are involved, it is desirable to have two casings, so that part of the shock can be transmitted to the second casing. This type of die is constructed with the casing containing the insert hardened to approximately Rc 55/56, while the outer casing is hardened to Rc 45/50. Both casings should be made of the same material. No. 883® alloy can be considered for this application because it can be easily tempered to both hardening ranges.

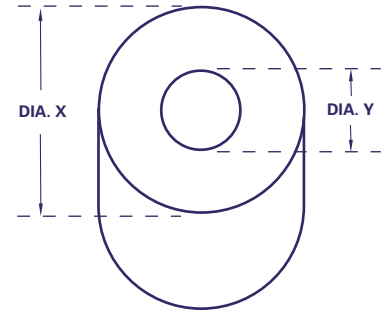

DIA. X =  $2\frac{1}{2}$ " DIA. Y MINIMUM  
CASING O.D. TO I.D. RELATIONSHIP IS CRITICAL

Fig. 40

Fig. 41

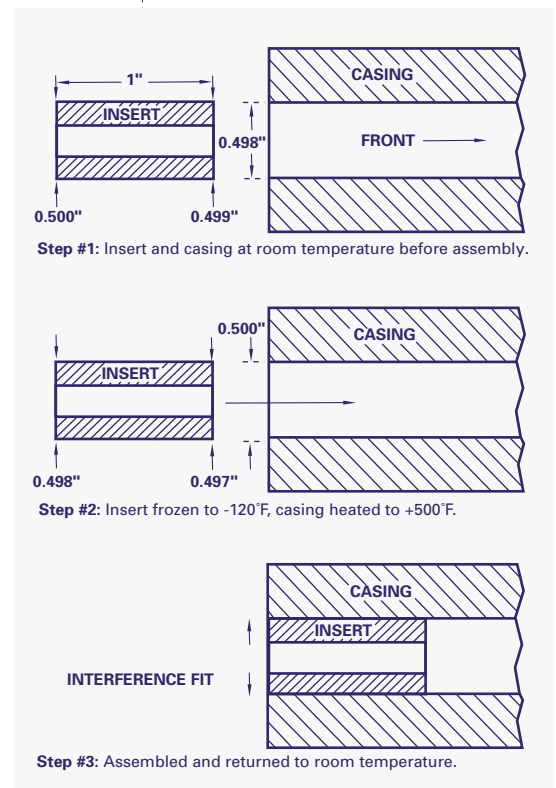

## Heading Die Construction for Cold Forming Extrusions

### Angles and Diameters

In a standard extrusion process for bolts consisting of a grip (unthreaded area) and a pitch diameter (threaded area), normal industry practice has been to use an included extrusion angle of 28°. This 28° angle has been readily accepted and is most successful because the thread blends into the angle (Figure 42).

The extrusion area, usually referred to as the land or choke, is normally 10 to 15 percent of the major diameter; i.e., grip = 0.245" diameter, land sizing diameter = 0.214", length of land = 0.030" to 0.035". The relief area (0.2155" to 0.216") is approximately 0.0015" larger than the land diameter. This will vary with the diameter of the extruded section.

General rule: In the sizes larger than  $\frac{3}{16}$ " (0.187") the length of the land is usually 10 percent of the major diameter—generally not to exceed 0.050". In diameters smaller than  $\frac{3}{16}$ " (0.187") the land is usually 15 percent of the major diameter with a maximum length of 0.030" and a 0.015" minimum length.

The pointing angle, normally associated with a starting lead when applying the fastener in assembly, is generally specified by the customer.

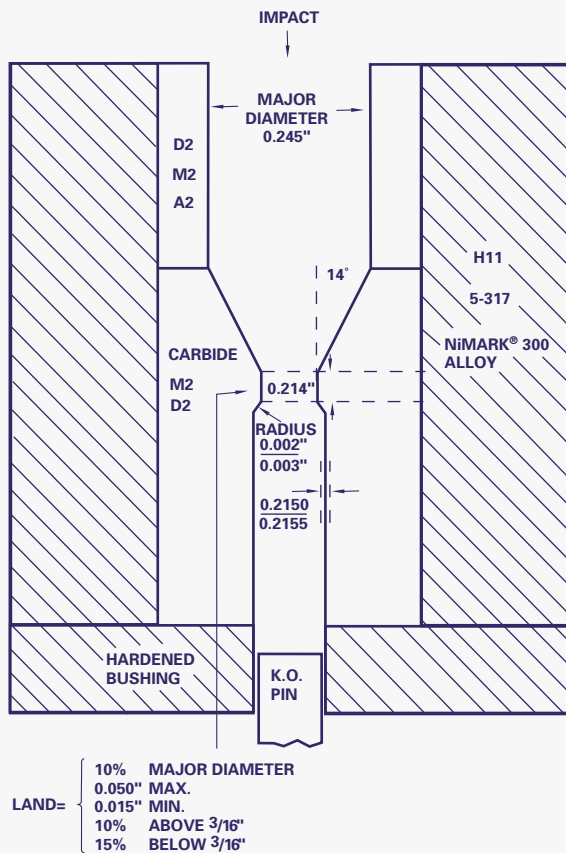

Fig. 42

## Die Problems

### Inserts

Failure of the inserts due to cracking is one of the heading industry's most vexing problems. When the proper grade of steel is used and heat treated correctly, cracking failures can usually be attributed to improper interference stress (support) or incorrect ratio of insert O.D. to casing O.D. This situation can be rectified by careful evaluation and the establishment of a record system keyed to each diameter of insert casing, interference allowance and tonnage for assembly of insert and casing. The I.D. configuration of insert must be taken into consideration.

When extremely complex configurations are to be formed in a die, it may be necessary to use a segmented insert which is usually introduced into a bushing that was made from Micro-Melt® M4 alloy (hardened to approximately Rc 58-60). The segmented sections and bushing, in turn, are introduced into a casing made from NiMark® 300 alloy.

The use of segmented sections in the insert construction allows maximum "breathing" to occur, which absorbs initial impact pressures—a significant advantage for the cold header.

### **Casing**

Good casing design and material are also very important so that the insert is allowed to breathe. For extremely heavy extrusions, a maraging steel such as NiMark 300 alloy at Rc 50-52 should be considered for the casing material. For normal extrusions, H-11 or H-13 may be used at a hardness of Rc 42-47.

### **Finish**

Alloy and tool steel selection for the insert depends upon part configuration requirements and the alloy being formed. Surface conditions of the extruding angle, land and relief must be extremely smooth to reduce extruding friction pressures. Normally, restrictions on the surface finish of these tools are requested at RMS Zero with the final finish a matter of negotiation.

### **Relief**

Relief is very critical for successful extrusions. If excessive relief is present, the extruded section will upset against the knockout pin and must then be extruded when ejected from the die. This will result in a bent extruded area which cannot be economically thread rolled on an automatic machine.

## **Other Factors that Affect Tool Performance**

### **Shearing**

The sheared wire which is subjected to the extrusion process must be sheared cleanly with a minimum squareness of 3° to 4°. If the sheared angle is not square (within 3° to 4°), uneven pressures on the extruding angle will develop, resulting in galling or a die buildup. This consequence will create friction problems, accelerated tool wear, and, in many instances, tool breakage.

### **Uniform Hardness and Column Strength**

When it is necessary to extrude the shank as well as that portion of the part formed in the traveling first or second punch, it is extremely important that timing be utilized and that the material being formed be of uniform tensility. If the alloy being formed lacks uniform tensility, an upsetting will occur between the die and traveling punch creating a malfunction and subsequent tool breakage.

Often the manufacturer of the cold formed part complains about the column strength of the cut-off slug to be extruded. The following guide may be helpful.

General rule: Stainless and high temperature alloys possessing minimum 75 ksi (517 MPa) ultimate tensility usually have adequate column strength for extrusion if all the other ground rules mentioned are observed. Actually, the higher the column strength, the easier the extrusion will be. When extruding and upsetting are required, it is suggested that your steel supplier be consulted.

### Lubricants

When using high temperature and stainless alloys, the coating is of utmost importance. The base material must be shrouded with an adequate coating impregnated with a lubricant to reduce friction. However, in many cases, wet drawing lubricants are utilized to supplement the lubricants which have been impregnated into the copper. Although a practice for many years, it can result in accelerated die wear and excessive tool breakage because the additional oil functions as a hydraulic action and exerts undue pressure on the tooling.

### Wire Extrusion

#### By-Product Advantage

An additional advantage in using the extruding process is that larger diameter wire can be used, which reduces the ratio of wire vs. the upset area. Normally,  $2\frac{1}{4}$ " wire diameters (shank dia.) are used as the ratio for one upset. By extruding, it is not unrealistic to establish five to eight shank diameters in the finished upset; i.e., use of wire having a  $\frac{3}{16}$ " diameter would prevent the formation of the head in Figure 43 because the volume of material in the head is approximately seven times the smaller diameter. By extruding, the head can be reduced to a controllable volume so that the use of a larger wire will be helpful (Figure 43).

### Heavy Extrusions

For particularly heavy extrusions, such as those shown in Figure 44, many experiments and practices are utilized throughout the industry. One such practice is to extrude as rapidly as possible using an extruding angle of  $45^\circ$  to reduce the pressure buildup within the tools. A second is to use a radial-bottomed extruding die which reduces die pressures by as much as 30 percent.

The importance of speed when extruding is a controversial subject. In general, the faster the materials are moved in an extrusion process, the less die pressure buildup will be encountered and the easier the process will be. Although, there is a limit as to how fast the material can be moved, depending on the alloy being extruded.

However, if the tooling is adequately designed (i.e., supported), speed usually does not have any relation to the success or failure of the extrusion.



Fig. 43



Fig. 44



## Chapter 5 Selected Hints

### Introduction

In the first four chapters of **Heading Hints** much of the information centers on the basics of cold forming. This chapter provides more detailed information on selected cold heading practices, including warm heading, tubular rivets, hex head cap screws, thread rolling, secondary operations and calculation methods for upset volumes.

### Warm Heading

Warm heading is a modified form of cold heading performed at 200° to 800°F (93° to 427°C), which is below the recrystallization point or transformation temperature of the metal being formed. Warm heading alloys working difficult-to-form materials, requires less deformation pressure, reduces tooling loads by as much as 50 percent compared to cold forming, and generally prolongs tool life.

Warm heading is especially applicable to parts of unusual shape and forming high strength alloys that are resistant to heat and corrosion. Usually alloys that work harden rapidly can be severely upset without cracking. The method generally works well for making high strength bolts from grades such as the austenitics and high temperature alloys like Pyromet alloy A-286, Waspaloy and Pyromet alloy 718.

With warm heading, the wire is usually heated before it enters the feed rolls, or, when possible, between the feed rolls and the header machine frame. The most commonly used methods of heating are:

1. Resistance Heating—A contact stand is installed between the wire reel and the feed rolls. A low-voltage, high-amperage circuit is then connected to the contact stand and the feed rolls. The electrical resistance of the metal itself serves to produce the heat.
2. Gas Heating—A series of burners is mounted on an adjustable stand and the wire passes over them. Variations include use of a tube, surrounded by a series of ring burners, which is mounted on an adjustable stand, heating the wire as it passes through the tube.
3. Induction Heating—An induction coil is installed in front of the feed rolls, and the wire is passed through the coil.

### The Importance of Temperature Control

Close control of wire temperature is important since erratic heating causes uneven flow, and results in uncontrolled head dimensions. If the wire is overheated, for instance, the material will tend to blob instead of flow. Also, the lubricity of the wire coating may be destroyed,

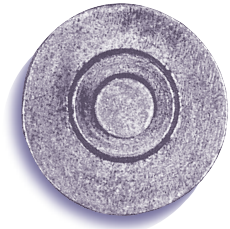

**Fig. 45** This end-on view of a fastener that was made from No. 10 stainless clearly shows a typical benefit of warm heading. Notice the size of the head relative to the diameter of the shank. Such severity of upsetting would be impossible with cold heading. This fastener was warm headed in two blows.

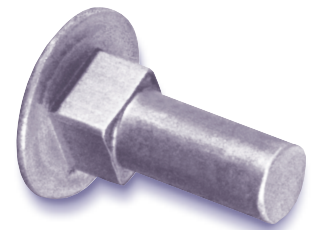

**Fig. 46** This truss square shoulder bolt, made from No. 10 stainless, was warm headed successfully. Less forming pressure was required on the die which increased tool life.

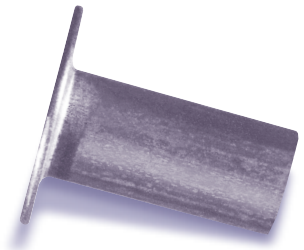

**Fig. 47** This Phillips® recessed wafer-head screw, made from Carpenter A-286, is another typical fastener made possible only by warm heading. The recess actually extends into the shank.



**Fig. 49** These Phillips® head sheet metal screws made from Type 305 stainless show the difference between cold and warm heading. The one on the right was warm headed successfully. The two on the left, however, were cold headed and have obvious defects. Stress cracking is the cause, not surface imperfections.

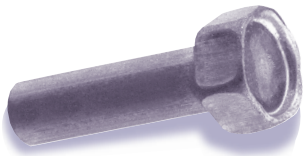

**Fig. 50** Warm heading enabled successful fabrication of this indented hex head screw that was made from Type 305 stainless.



**Fig. 51** Warm heading eliminated stress cracking for the severe upset of this truss shoulder bolt made from Carpenter No. 10 stainless.

and smearing may occur at the cut-off station. Close temperature control, on the other hand, improves plasticity and headability by reducing both the strength and work hardening of the material being formed. Consequently, less forming pressure is required to fill the cavity of the die or hammer, with a resulting improvement in sharper corners and shoulders and, in some cases, elimination of stress cracking.

Surprisingly good warm heading results for the stainless steels are achieved in the temperature range between 350° and 450°F (177° to 232°C). Temperatures over 600°F (316°C) should generally be avoided. A typical example is an increase in piercer punch life from 2,000 to 10,000 parts in forming M6 nuts in Type 305 stainless. Valve lifter rollers and inner and outer bearing races are easier to fabricate using warm heading.

See Chapter 3 for a discussion of warm and hot heading lubricants.

Testing Temperature °F      °C		Tensile Strength			
		Annealed Wire		Lightly Drawn Wire	
		ksi	MPa	ksi	MPa
Room	Room	74	510	83	572
250	121	68	469	—	—
300	149	—	—	73	503
400	204	—	—	71	490
500	260	60	414	70	483
750	399	59	410	—	—
1000	538	56	386	—	—

**Fig. 48** This chart shows typical tensile strength variation for stainless wire at elevated temperatures.

### Tubular Rivets

The manufacture of low-carbon steel tubular rivets by cold heading is common practice (Figure 52). Fabrication is relatively simple with steels such as AISI Type 1006. However, increasing demand for 18-8 stainless or austenitic tubular rivets has created a number of production problems, even though many producers of cold formed parts have been able to manufacture tubular rivets from Types 410 and 430 stainless steel with very slight changes in tooling and practice.

The cold working of 18-8 stainless into tubular shapes (or any of the 18-8 alloy modifications such as Carpenter No. 10 alloy [Type 384] and Custom Flo 302HQ alloy) has proven to be more difficult than forming the low-carbon grades.

Prior to the introduction of modified stainless steels and improved manufacturing techniques, tubular rivets made from austenitic alloys had always been drilled rather than extruded. The specialized techniques and practices that have been developed are necessary for the successful extrusion of these more difficult alloys. Compared with drilling, extrusion is a low-cost operation that results in significant savings to the users of tubular rivets.

Some headers have produced tubular rivets from Carpenter 302HQ alloy using a single-die, two-blow header. The ability to deliver two blows allows the first punch to start the metal in a given direction, so that it may be finished with the second blow. In order to form a tubular rivet configuration, modification of the knockout station is required.

Other fabricators have found they can achieve a greater level of efficiency using a standard rivet header—a two-station, two-die machine. This machine is essentially comprised of two single-blow headers mounted side-by-side on a common base with provisions for the mechanical transfer of parts from the first die to the second. Usually the first station squares the cut-off slug to a maximum squareness not to exceed one or two degrees out of square. The slug is then transferred to the second die where it is pierced and/or extruded depending upon the process being used by the header.

### Some Important Considerations

In any 18-8 stainless tubular rivet program—using either single or multiple dies—it is extremely important to devote particular attention to the initial wire diameter, the shearing of the wire, and the squareness of the cut-off.

Another important consideration is tooling. It is not uncommon for an extruding pin at a hardness of Rc 63 to upset prior to extruding, and subsequently shear due to the uneven pressures exerted upon it. A hardness of Rc 65 is suggested as the minimum hardness level for the extruding pin with an optimum hardness of Rc 66 or 67. Field reports indicate that using titanium carbide and nitride vapor deposition techniques are helpful in prolonging extruding pin life.

Proper design of the extruding pin is critical. Many different pin designs are considered proprietary; however, one of the most common configurations is a 5° angle at the face of the pin with the length of the land on the pin equivalent to the sidewall of the tubular rivet (not to exceed 0.030" in length)(Figure 53).

Most fabricators have found it helpful to use warm heading techniques when forming tubular rivets from an austenitic alloy. Resistance, induction and gas heaters are commonly used for this purpose, although many heading shops favor the resistance method. Tubular rivets that were made from 18-8 modified stainless are usually formed at a temperature of 750°F (399°C) (Figure 54).



**Fig. 52** These are examples of tubular rivets successfully cold headed from stainless alloys.

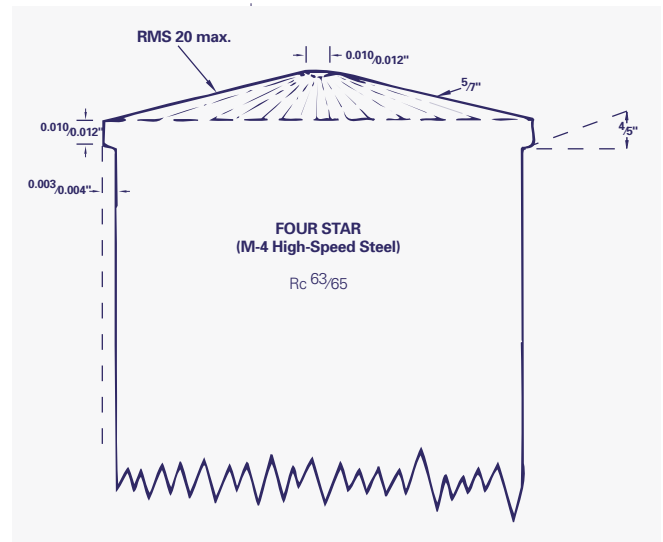

**Fig. 53** Cone point extrusion pins have been used successfully in the production of low-carbon steel tubular rivets. Use of the cone point design to extrude similar parts from the 18-8 stainless steels, on the other hand, is detrimental to the final product. It is suggested that a flat be machined on the face of the pin equivalent to the length of the land. By doing this, the extrusion will perform in a waterfall pattern rather than in a piercing pattern.

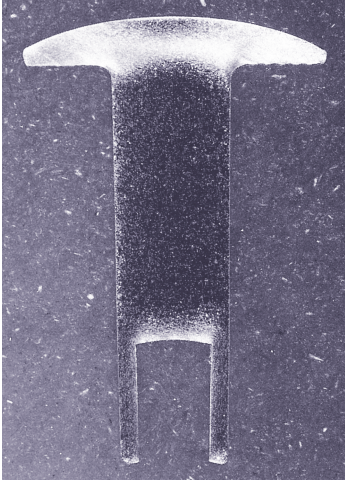

**Fig. 54** Warm heading contributes to better tubular rivet production from the austenitic alloys. Temperatures of 750°F work best, but heading in the 850° to 900°F range may further increase tool life.

Additional experience has shown that temperatures between 800° and 900°F (427° and 482°C) are most beneficial in extending tool life and extending efficiency of the extruding pin. Lubricants are needed, too, for successful forming. Common practice involves installing an oil cup in the die block so the extruding pin is lubricated with oil coolant on the backward stroke.

### Hex Head Cap Screws

Various practices used in the manufacture of stainless steel hex head cap screws have a direct effect upon trim die life. Some manufacturers have developed the technique of using a single-die, two-blow header that forms the wafer section on the first upset. The cold formed part is then transferred into a trimmer and the hex is formed on the head of the cap screw (Figure 55).

This simple operation seems effective provided special trimming dies are used, the correct tool design and steel are chosen, and the proper techniques to control flow pattern are developed.

Extremely poor trim die life is experienced, however, whenever this process is pursued to the fullest extent. In many cases, the wafer cold headed part must be bright annealed before being transferred to the trimming station for hex head formation.

Average trim die life without annealing is approximately 6,000 parts. When annealing is used as an intermediate step, die life increases to 12,000 to 14,000 parts.

Use of a two-die, four-blow, and/or progressive header is a much more efficient method of production for hex head cap screws. With progressive heading the blank is automatically transferred to a series of dies for a number of multiple blows.

In the progressive forming sequence, a larger wire diameter is used and the blank is extruded at the first station with the headed portion remaining unworked. After automatic transfer to the second station, additional extrusion is performed if necessary, plus wafering of the headed area. The part is subsequently shifted to a final station where it is trimmed. Trim die life is approximately 20,000 to 25,000 parts per tool using this method.

It is important that the condition of the wire being used for progressive heading has a coating to support extrusion. An example is a tightly adhering copper coating with an overcoat. Carpenter suggests application of an Ecolube II overcoat for ultimate production results. This improves tool efficiency and reduces downtime.

Recently some hex head cap screw fabricators have found it beneficial to use a sectional carbide trimming die (Figure 56) to trim the blank. This sectional die reduces compressive loads and

**Fig. 55** A single-die, two-blow heading machine forms the wafer section on this hex head cap screw on the first upset. The cold-formed part is then transferred to a trimmer where the hex is formed.



increases the die life to approximately 50,000 to 60,000 parts per tool before resharpener. Sectional dies should be evaluated for cost considerations since these dies are about five times more expensive than solid, high-speed tool steel dies.

Hex head cap screws have been commonly used throughout the automotive, construction and machine tool industries. Such stainless alloys as Carpenter 302HQ stainless and 20Cb-3® stainless and Type 316 stainless are formed easily with proper techniques (Figure 57).

### Thread Rolling

For thread rolling, what is the best wire size and the proper heading blank diameter necessary for superior results? The answer is not always simple. Choice of an optimum starting wire must conform to the thread limitations as specified in the standards.

Two approaches to solving this problem predominate. One school of thought dictates that the tolerances on the header be maintained at approximately 0.002", while the other approach recommends that the blank diameter be controlled at a total tolerance of 0.001" with die pressure relieved in the rolling process.

Of course, headed blank diameter varies with the alloy being formed, and easy-to-move materials, including AISI Type 1010, 1018, 410, 430 and aluminum, present few thread rolling problems. However, alloys with a higher rate of work hardening, such as Type 305, A-286, Waspaloy and Pyromet 718 alloy, fall into a different category.

Initially when heading these harder-to-work alloys, it is strongly recommended that a diameter wire as large as possible be used while still maintaining dimensional tolerances. Experience shows that blank size tolerances from the header should be held both:

1. To the narrower 0.001" tolerance band, and
2. To the high side of the pitch diameter in order to reduce roll threading problems.

Experience has also shown that by controlling the blank diameter on the header, roll thread die life is improved.

The indicated blank diameters relating to basic alloys are suggested as a working guide along with the standardized wire diameter to be used (Figures 58 and 59).

Use of these standard wire sizes actually reduces the volume of deformation in the area upset, restricts the blank diameter from the heading machine to a maximum of 0.0015" total tolerance, and also minimizes thread rolling die wear. The 0.0015" total tolerance is usually adequate if proper heading die design and steel are used.

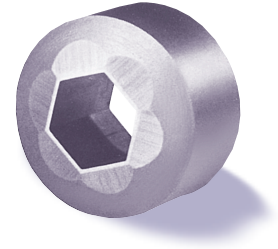

**Fig. 56** A sectional carbide trimming die reduces compressive loads and increases die life in hex head cap screw fabrication.



**Fig. 57** This is an example of the type of hex head cap screw being successfully headed from stainless steel today.

Size	Headed Body Tolerance	Wire Size
# 2	.073/.075	.072
# 3	.083/.085	.082
# 4	.094/.096	.093
# 6	.112/.114	.111
# 7	.124/.126	.123
# 8	.133/.135	.132
# 9	.141/.143	.140
#10	.149/.151	.148
#12	.174/.175	.173
#14	.201/.203	.200
#16	.219/.222	.218
#18	.240/.243	.239
#20	.265/.268	.264
#24	.319/.322	.318

**Fig. 58** Alloys that can be considered for tapping screws (Types 410, 305, 304, 18-8 and 302HQ) should be sized according to this table.

Machine Screw Size	Carbon Steel	Brass, Bronze, Type 410 Aluminum, Type 430	Stainless 18-8 & Custom Flo 302 HQ	Wire Size
2-56	.072/.0735	.0725/.0738	.073/.073	.072
2-64	.0735/.075	.074/.0755	.0745/.0755	.073
3-44	.082/.0835	.0825/.084	.083/.0845	.082
3-48	.083/.0845	.0835/.085	.084/.085	.083
3-52	.0835/.085	.084/.0855	.0845/.086	.083
3-56	.085/.0865	.0855/.087	.086/.087	.085
4-32	.089/.091	.0895/.0915	.090/.0915	.089
4-36	.091/.0925	.0915/.093	.092/.0935	.091
4-40	.093/.0945	.0935/.095	.094/.0955	.093
4-48	.096/.0975	.0965/.098	.097/.098	.096
5-40	.106/.1075	.1065/.108	.107/.108	.106
5-44	.1075/.109	.108/.1095	.1085/.110	.107
6-32	.1155/.1165	.1155/.117	.116/.117	.115
6-36	.117/.1185	.1175/.119	.118/.1195	.117
6-40	.119/.1205	.1195/.121	.120/.1215	.119
6-56	.1235/.125	.124/.1255	.1245/.126	.123
7-32	.128/.130	.1285/.1305	.129/.1315	.128
8-30	.1395/.141	.140/.1415	.1405/.142	.139
8-32	.141/.1425	.1415/.143	.1415/.1425	.140
8-36	.143/.1445	.1435/.145	.144/.1455	.143
8-40	.144/.1455	.1445/.146	.145/.1465	.144
9-32	.153/.1545	.1535/.155	.154/.1555	.153
10-24	.160/.1615	.160/.162	.1605/.162	.160
10-30	.1655/.1675	.166/.168	.1665/.168	.165
10-32	.1665/.168	.167/.1685	.1675/.1685	.166
12-24	.185/.187	.1855/.1875	.186/.1875	.185
1/4-20	.214/.216	.2145/.2165	.215/.217	.214
1/4-28	.223/.225	.2235/.2255	.224/.2255	.223
5/16-18	.272/.2745	.2725/.274	.273/.275	.271
5/16-20	.275/.277	.2755/.277	.276/.278	.273
5/16-24	.281/.284	.2815/.2845	.282/.285	.280
3/8-16	.3295/.3325	.330/.333	.3305/.333	.328
3/8-24	.3435/.346	.344/.3465	.3445/.3465	.342
1/2-13	.444/.447	.4445/.4475	.445/.448	.443

**Fig. 59** These are recommended blank diameters and appropriate standard wire sizes for thread rolling. Note that coatings should be taken into consideration when establishing the proper blank diameter prior to mill threading.



**Fig. 60** These spoke nipples for car and motorcycle wheels were made from Carpenter 302HQ-FM® stainless, which offers good headability and free machining fabricability characteristics in the same stainless alloy.

### Accommodating Secondary Operations

It is possible to tailor many of today's headable stainless grades to accommodate secondary operations, especially machining. Adding controlled amounts of sulfur to Type 305 stainless, for example, can improve this grade's machinability. Any addition, of course, is within, but at the top of, non-free-machining analysis limits. The intention is to provide a headable grade that is as clear and free from internal chip breaking elements as possible.

An excellent example is that experienced by a manufacturer of spoke nipples (Figure 60) for motorcycle and automobile wheels who gained advantages by switching to Carpenter 302HQ-FM® stainless. This grade was designed specifically for applications requiring secondary machining operations after primary cold forming.

Several versions of stainless steels were tested, including Type 303 with additions of selenium or sulfur. These cracked, however, during cold heading, would not extrude properly or caused other fabrication problems.

Type 302HQ-FM stainless provided desired properties for the spoke nipples. In addition to offering improved corrosion resistance and the optimum combination of cold heading and machining fabrication characteristics, it proved to be competitive with previous raw material and production costs, had the necessary anti-galling properties, and provided sufficient luster on finished parts.

This manufacturer used 302HQ-FM stainless in two wire sizes—0.278" and 0.297"—cold drawn with an Ecolube II coating. Coiled wire was fed into a solid-die, double-stroke header, forming the entire outside dimensions (slot and head) at the rate of 72 parts per minute. These nipple blanks were then run through an eight-station rotary machining center that included operations such as milling, relief drilling, tapping and threading. These operations were performed at the rate of five parts per minute. Total fabricating time was 13 seconds per part. Machined spoke nipples were finally tumbled, degreased and washed.

### Calculation Methods for Upset Volumes

Three excellent methods exist for calculating the volume of material for cylindrical upsets. The first, discussed briefly in Chapter 1, uses the formula shown in Figure 61.

Upset volume may also be calculated based on unit weights. Figure 62 provides the weights of unit lengths of steel wire for use in the following formula:

$$h = \frac{W_D H}{W_d d}$$

Figure 62 offers a sample calculation for 0.625" diameter wire. This same method may be used to determine the number of diameters in heads of complicated shape.

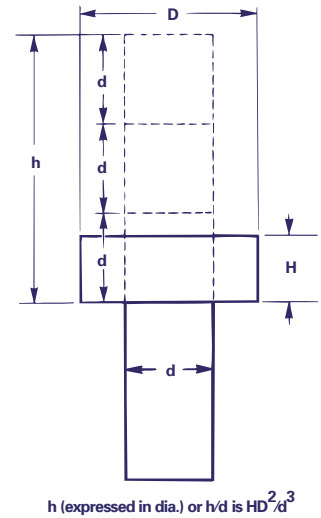

**Fig. 61** This formula, where D is the finished diameter and H the height of the completed upset, is one method of calculating volume for cylindrical upsets.

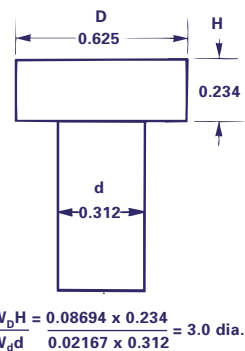

**Fig. 62** Another way to calculate the number of diameters required for cylindrical upsets is this one based on weights of unit lengths of steel wire.

First, weigh a sample part accurately. Next, determine the shank weight by locating the diameter in Figure 63 and multiplying this unit weight by the shank length. This shank weight is then subtracted from the total part weight. The remainder is the head weight or the WDH in the formula on page 53.

The third method uses the nomograph calculation shown in Figure 64.

**Fig. 63** The weight of unit lengths of steel wire needed to use the volume calculation formulation in Figure 62. Weight is shown in 0.001 lb.

Diam	0.000	0.100	0.200	0.300	0.400	0.500	0.600	0.700	0.800	Diam	0.000	0.100	0.200	0.300	0.400	0.500	0.600	0.700	0.800
0.000		2.23	8.90	20.03	35.61	55.64	80.13	109.06	142.45	0.050	0.556	5.01	13.91	27.27	45.07	67.33	94.04	125.20	160.82
0.001		2.27	8.99	20.17	35.79	55.87	80.39	109.38	142.81	0.051	0.579	5.07	14.02	27.42	45.27	67.57	94.33	125.53	161.19
0.002		2.32	9.08	20.30	35.97	56.09	80.66	109.69	143.17	0.052	0.602	5.14	14.13	27.58	45.47	67.82	94.62	125.87	161.57
0.003		2.36	9.17	20.43	36.15	56.31	80.93	110.00	143.52	0.053	0.625	5.21	14.25	27.74	45.68	68.07	94.91	126.20	161.95
0.004		2.41	9.26	20.57	36.33	56.53	81.20	110.31	143.88	0.054	0.649	5.28	14.36	27.89	45.88	68.31	95.20	126.54	162.33
0.005		2.45	9.35	20.71	36.51	56.76	81.47	110.63	144.24	0.055	0.673	5.35	14.47	28.05	46.08	68.56	95.49	126.88	162.71
0.006		2.50	9.45	20.84	36.68	56.99	81.74	110.94	144.60	0.056	0.698	5.42	14.59	28.21	46.28	68.81	95.78	127.21	163.09
0.007		2.55	9.54	20.98	36.87	57.21	82.01	111.26	144.95	0.057	0.723	5.49	14.70	28.37	46.48	69.05	96.08	127.55	163.47
0.008		2.60	9.63	21.12	37.05	57.44	82.28	111.57	145.31	0.058	0.749	5.56	14.82	28.53	46.69	69.30	96.37	127.89	163.86
0.009		2.64	9.72	21.25	37.23	57.67	82.55	111.89	145.67	0.059	0.774	5.63	14.93	28.69	46.89	69.55	96.66	128.22	164.24
0.010		2.69	9.82	21.39	37.41	57.89	82.82	112.20	146.03	0.060	0.801	5.70	15.05	28.85	47.10	69.80	96.95	128.56	164.62
0.011		2.74	9.91	21.53	37.60	58.12	83.09	112.52	146.40	0.061	0.828	5.77	15.16	29.01	47.30	70.05	97.25	128.90	165.00
0.012		2.79	10.00	21.67	37.78	58.35	83.36	112.84	146.76	0.062	0.856	5.84	15.28	29.17	47.50	70.30	97.54	129.24	165.39
0.013		2.84	10.10	21.81	37.96	58.58	83.64	113.15	147.12	0.063	0.883	5.91	15.40	29.33	47.71	70.55	97.84	129.54	165.77
0.014		2.89	10.19	21.95	38.15	58.80	83.91	113.47	147.48	0.064	0.911	5.99	15.51	29.49	47.92	70.80	98.13	129.92	166.15
0.015		2.94	10.29	22.09	38.33	59.03	84.18	113.79	147.84	0.065	0.940	6.06	15.63	29.65	48.13	71.05	98.43	130.26	166.54
0.016		2.99	10.38	22.23	38.52	59.26	84.46	114.11	148.21	0.066	0.970	6.13	15.75	29.82	48.33	71.30	98.73	130.59	166.93
0.017		3.05	10.48	22.37	38.70	59.49	84.73	114.43	148.57	0.067	0.999	6.21	15.87	29.98	48.54	71.56	99.02	130.94	167.31
0.018		3.10	10.58	22.51	38.89	59.72	85.01	114.75	148.93	0.068	1.03	6.28	15.99	30.14	48.75	71.81	99.32	131.28	167.70
0.019		3.15	10.68	22.65	39.08	59.95	85.29	115.07	149.30	0.069	1.06	6.36	16.11	30.31	48.96	72.07	99.62	131.63	168.08
0.020		3.20	10.77	22.79	39.26	60.19	85.56	115.39	149.66	0.070	1.09	6.43	16.23	30.47	49.17	72.32	99.92	131.97	168.47
0.021		3.26	10.87	22.93	39.45	60.41	85.84	115.71	150.03	0.071	1.12	6.51	16.35	30.64	49.38	72.57	100.21	132.31	168.86
0.022		3.31	10.97	23.08	39.64	60.65	86.11	116.03	150.39	0.072	1.15	6.58	16.47	30.80	49.59	72.82	100.51	132.65	169.25
0.023		3.37	11.07	23.22	39.83	60.88	86.39	116.35	150.76	0.073	1.19	6.66	16.59	30.97	49.80	73.08	100.81	133.00	169.63
0.024		3.42	11.17	23.37	40.01	61.12	86.67	116.67	151.13	0.074	1.22	6.74	16.71	31.13	50.01	73.33	101.11	133.34	170.02
0.025		3.48	11.27	23.51	40.20	61.35	86.94	116.99	151.49	0.075	1.25	6.82	16.83	31.30	50.22	73.59	101.41	133.69	170.41
0.026		3.53	11.37	23.65	40.39	61.58	87.22	117.32	151.86	0.076	1.29	6.89	16.96	31.47	50.43	73.85	101.71	134.03	170.80
0.027		3.59	11.47	23.80	40.58	61.82	87.50	117.64	152.23	0.077	1.32	6.97	17.08	31.63	50.64	74.10	102.01	134.38	171.19
0.028		3.65	11.57	23.95	40.77	62.05	87.78	117.96	152.60	0.078	1.35	7.05	17.20	31.80	50.86	74.36	102.32	134.72	171.58
0.029		3.70	11.67	24.09	40.96	62.29	88.06	118.29	152.97	0.079	1.39	7.13	17.33	31.97	51.07	74.62	102.62	135.07	171.98
0.030		3.76	11.77	24.24	41.16	62.52	88.34	117.61	153.34	0.080	1.42	7.21	17.45	32.14	51.28	74.87	102.92	135.42	172.37
0.031		3.82	11.88	24.39	41.35	62.76	88.62	118.94	153.70	0.081	1.46	7.29	17.58	32.31	51.50	75.13	103.22	135.77	172.76
0.032		3.88	11.98	24.53	41.54	62.99	88.90	119.26	154.08	0.082	1.50	7.37	17.70	32.48	51.71	75.39	103.53	136.11	173.15
0.033		3.94	12.08	24.68	41.73	63.23	89.19	119.59	154.44	0.083	1.53	7.45	17.83	32.65	51.92	75.65	103.83	136.46	173.54
0.034		4.00	12.19	24.84	41.92	63.47	89.47	119.92	154.82	0.084	1.57	7.54	17.95	32.82	52.14	75.91	104.14	136.81	173.94
0.035		4.06	12.29	24.98	42.12	63.71	89.75	120.24	155.19	0.085	1.61	7.62	18.08	32.99	52.36	76.17	104.44	137.16	174.33
0.036	0.288	4.12	12.40	25.13	42.31	63.95	90.03	120.56	155.56	0.086	1.65	7.70	18.21	33.19	52.57	76.43	104.74	137.51	174.72
0.037	0.305	4.18	12.50	25.28	42.50	64.18	90.32	120.90	155.93	0.087	1.68	7.78	18.33	33.33	52.79	76.69	105.05	137.86	175.12
0.038	0.321	4.24	12.61	25.43	42.70	64.42	90.60	121.23	156.31	0.088	1.72	7.87	18.46	33.51	53.00	76.95	105.36	138.21	175.52
0.039	0.338	4.30	12.71	25.58	42.90	64.66	90.88	121.56	156.68	0.089	1.76	7.95	18.59	33.68	53.22	77.22	105.66	138.56	175.91
0.040	0.356	4.36	12.82	25.73	43.09	64.90	91.17	121.88	157.05	0.090	1.80	8.03	18.72	33.85	53.44	77.48	105.97	138.91	176.31
0.041	0.374	4.43	12.93	25.88	43.29	65.15	91.45	122.21	157.42	0.091	1.84	8.12	18.85	34.03	53.66	77.74	106.28	139.26	176.70
0.042	0.393	4.49	13.04	26.03	43.48	65.39	91.74	122.54	157.79	0.092	1.88	8.20	18.98	34.20	53.88	78.01	106.58	139.62	177.10
0.043	0.411	4.55	13.14	26.19	43.68	65.63	92.03	122.87	158.18	0.093	1.92	8.29	19.11	34.38	54.10	78.27	106.89	139.97	177.50
0.044	0.431	4.62	13.25	26.34	43.88	65.87	92.31	123.21	158.55	0.094	1.97	8.38	19.24	34.55	54.32	78.53	107.20	140.32	177.89
0.045	0.451	4.68	13.36	26.49	44.07	66.11	92.60	123.54	158.93	0.095	2.01	8.46	19.37	34.73	54.54	78.80	107.51	140.68	178.29
0.046	0.471	4.74	13.47	26.65	44.27	66.35	92.88	123.87	159.30	0.096	2.05	8.55	19.50	34.90	54.76	79.06	107.81	141.03	178.69
0.047	0.491	4.81	13.58	26.80	44.47	66.60	93.17	124.20	159.68	0.097	2.09	8.64	19.63	35.08	54.98	79.33	108.13	141.39	179.09
0.048	0.513	4.88	13.69	26.96	44.67	66.84	93.46	124.53	160.06	0.098	2.14	8.73	19.77	35.26	55.20	79.60	108.44	141.74	179.49
0.049	0.534	4.94	13.80	27.11	44.87	67.08	93.75	124.87	160.44	0.099	2.18	8.81	19.90	35.43	55.42	79.86	108.75	142.09	179.89



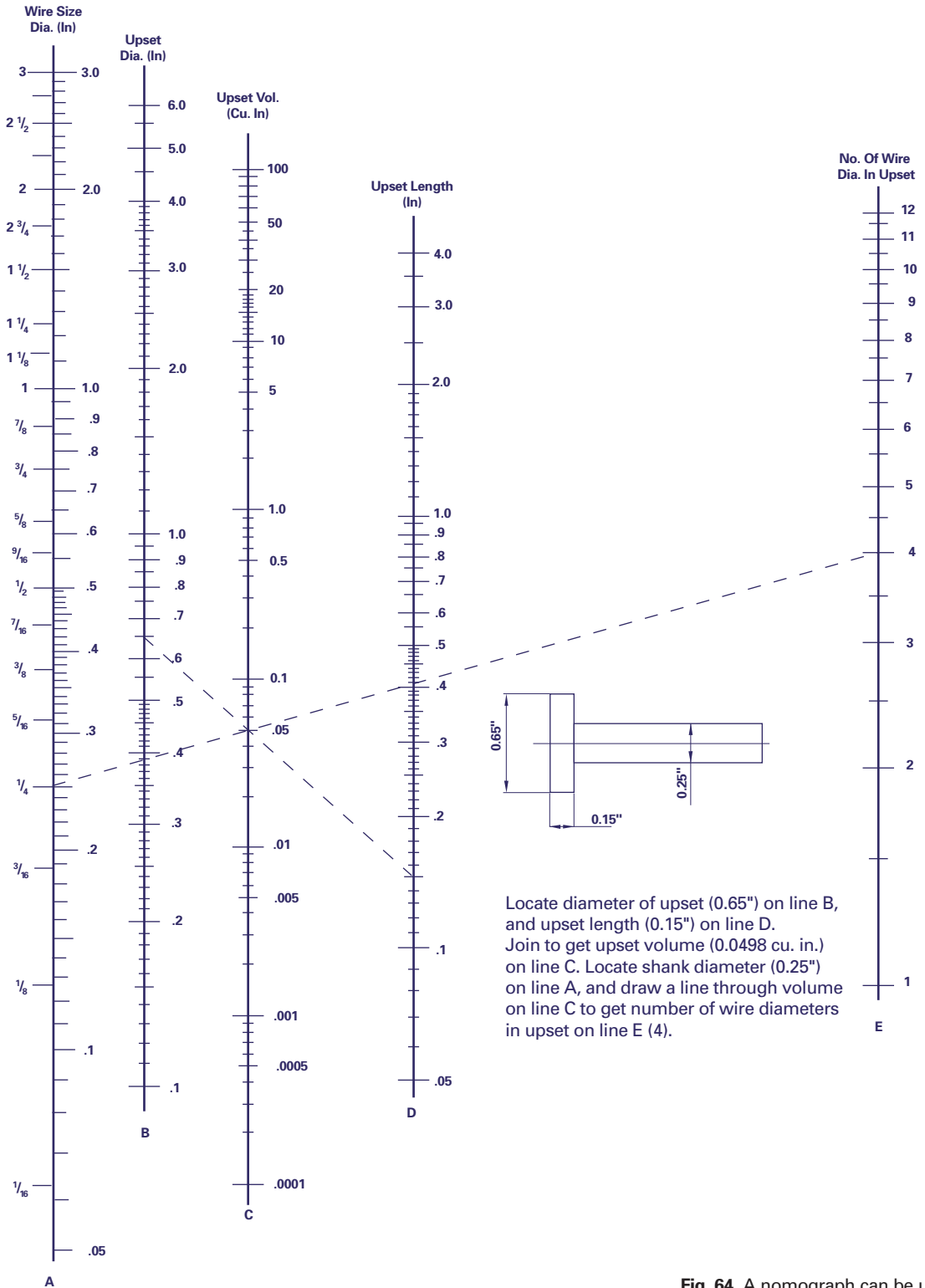

Courtesy of Industrial Fasteners Institute

**Fig. 64** A nomograph can be used to find the number of wire diameters required for cylindrical upsets. The example shown is for an upset 0.65" in diameter by 0.15" high formed wire 0.25" in diameter.

## Glossary

**Annealing:** Softening; a thermal cycle used to reduce the strength of wire or parts before or after cold forming.

**Area Reduction:** The percentage decrease of cross-sectional area produced by cold working prior to heading or by extrusion. Calculated by measuring the area of the original wire and dividing it by the area of the finished blank using the formula:

$$\%RA = 1 - \frac{\pi r_1^2}{\pi r_2^2}$$

where  $r_1$  is the original radius and  $r_2$  is the finished radius.

**Austenitic:** The term used to describe the structure of the non-magnetic, non-hardenable 300 series (18-8) stainless steel alloys.

**Backward Extrusion:** Forming with a punch and die so that metal is flowed between the bottom of the die and the face of the punch, flowing outward and rearward around the punch. (See Extrusion, Forward Extrusion.)

**Blank:** A piece of metal cut from a wire coil with specific size and mass that is formed into a finished part by the cold forming process. Also called a slug.

**Blow:** A term that describes the application of force to metal in the heading operation. One blow means the metal or blank is struck once. Heading machines are sometimes referred to in terms of the number of blows they deliver; i.e., a “two-blow, solid die header.”

**Coating:** Materials applied to heading wire or rod at the mill, such as soaps, greases, copper, molybdenum disulfide, etc. They are necessary to eliminate metal-to-metal contact in cold forming, and to make fabrication easier. Numerous coating combinations are possible.

**Coining:** Flattening the end of a cold formed part, usually used to denote a finishing cold forming operation in a multi-blow setup with a minimum of metal flow.

**Cold Forming:** A general term applied to a process in which metal is upset or extruded with a punch and die (basically forging without heat). Cold forming also describes closely related operations such as piercing, pointing, trimming, threading, and coining.

**Cold Shut Defect:** Describes a heading blank that has doubled over on itself due to the attempt to upset too many diameters in one blow.

**Cone:** Typical shape of a fastener head after the first blow in a multiple stroke header. For optimum grain flow, the apex of this truncated cone should have an included angle of approximately 12°.

**Crank Header:** Any type of heading machine that uses a crank, rather than toggle assembly, to move the ram or gate to deliver heading blows. Most heading machines use crank mechanisms.

**Critical Point:** The temperature or pressure at which a change in crystal structure, phase or physi-

cal properties occurs. Same as transformation temperature. (See Recrystallization.)

**Cut-off Knife:** The specially shaped blade that shears the blank from the wire coil held in the cut-off die (quill). It is equipped with a spring or other gripping mechanism for holding the sheared blank as it is transferred to the first heading die.

**Deformation:** A change in shape. In cold forming it occurs when enough force is applied to exceed the yield strength of the metal causing plastic flow.

**Diameters:** (See Free Length Ratio.) The relationship between the length of a blank and the diameter of the wire coil from which it was cut. Calculated by dividing the length of the blank by its diameter. A 5" blank of 1/2" wire is 10 diameters. Diameters are important in calculating the amount of blank or wire that can be upset in one blow; basic heading practice allows up to 2 1/4 diameter upset in one blow.

**Die:** A specially shaped block of hardened tool steel or carbide with a cavity that shapes the head of a fastener on a blank as it is forced into the die under great pressure or a varying diameter sized hole that causes a blank to extrude as the blank is forced into it. Most heading is done with solid dies. Open dies are used to produce longer shank parts.

**Die Spreader:** The cam-operated mechanism on an open die that forces the two halves of the die apart as each workpiece is finished.

**Extrusion:** A process that changes metal shape:

1. While a blank is pushed forward into a die with a smaller diameter opening than the blank itself, or
2. By creating a cavity or center hole by forcing the metal to flow backward over the punch. (See Backward, Forward Extrusion.)

**Extrusion Angle:** The angle of the opening of a solid die into which a blank is forced during extrusion. This angle should not exceed 30°.

**Feed Rolls:** A matched set of grooved rolls that feed heading wire from the coil into the cut-off die or quill. Feed rolls must be sized exactly to the diameter of the wire being headed.

**Ferritic:** The term used to describe the structure of stainless steels that are magnetic and non-hardenable by heat treatment. These are referred to as the “straight chrome” stainless grades, and contain from 14 to 27 percent chromium.

**Formability Range:** Lies between the metal’s yield strength (the point at which plastic flow begins) and tensile strength (the point at which the metal breaks). Cold forming takes place in this range. As it does, the yield strength increases faster than tensile strength, which decreases formability limits.

**Forward Extrusion:** Forcing wire or blank into a smaller die cavity, which reduces the original diameter, but increases length. This is

often combined with upsetting or partial upsetting to form higher head-to-shank diameter ratios. (See Backward Extrusion, Extrusion.)

**Free Length Ratio:** (Often referred to as “number of diameters”). The ratio of the length of wire to be headed protruding above the die to the diameter of the blank. High free length ratios may cause buckling of the stock or eccentric heads.

**Gate:** The heading machine component that drives the punch against the wire or blank, exerting tremendous pressure to force the workpiece against the die. Also called the ram.

**Grain Structure:** The internal makeup of the metal. Cold forming forces grain structure to flow with the new shape, thus resulting in increased strength. Other processes, such as machining, actually cut the grain structure, making the part weaker. The grain structure of stainless steels can either be ferritic, austenitic or martensitic.

**Hardenability:** The tendency of steel to harden upon heat treatment. Hardness, expressed in Rockwell or Brinell measurement, is a measure of the degree to which the steel actually hardens. Hardenability is influenced solely by alloy content.

**Head Cracking:** This occurs when the radial pressure caused by the compressive load of the upset process places circumferential fibers of the metal being formed in tension. These fibers can be

loaded to such an extent that ultimate strength is exceeded and head cracking results.

**Head Diameter Ratio:** Ratio of the diameter of the finished head to the diameter of the shank; a major index of heading severity. (See Upsetting.)

**Heading:** A cold forming process that literally means to form the head on a fastener via upsetting. It is mainly a room temperature process, but warm and hot heading are used for tougher alloys.

**Heading Pressure:** The pressure required to cold form a given material. A rule of thumb would be that any cold forming material can be given permanent new shape by applying a force equal to three times its yield strength, or two times its tensile value, whichever is greater. This rough rule indicates the machine tonnage needed to head a particular type of wire.

**High Temperature Alloy:** Also called superalloys, these are heavily alloyed metals with superior corrosion or oxidation resistance, strength or other properties. High capacity equipment is required to cold form these alloys.

**Insert Die:** A cold forming die made of a tough, strong casing with a hard, wear-resistant insert. Types of steel used in the casing and insert vary with the die’s purpose. The insert may be installed by press or shrink methods.

**Knockout Pin:** The part in a solid die header that either supports the blank, ejects finished parts

or does both during heading. Also called the knockout pin. No knockout pin is used in open die heading.

**Land:** The distance the blank is positioned in the die prior to extrusion. For forward or backward extrusion in an open die, the blank must “land”  $\frac{1}{8}$ " into the die for support just prior to the extrusion blow.

**Lubricant:** Materials applied during the actual heading operation, including mineral oils, soaps, greases, etc. Many include coatings in the term, lubricant, though for purposes of this book, coatings are considered materials applied at the mill. (See Coating.)

**Machining:** A metalworking process that includes such operations as turning, drilling, broaching, tapping, threading, milling, etc., in which material is cut away to form a finished part.

**Martensitic:** The term used to describe the structure of stainless steels that are hardenable by heat treatment. They are also known as “straight chrome” grades. They include many of the 400 series grades; all are magnetic.

**Maximum Heading Capacity:** The specification for a heading machine, usually expressed in tons, that describes the force required to upset a carbon steel carriage bolt head from the maximum wire diameter the machine is capable of running.

**Molybdenum Disulfide:** A major lubricant or coating component used widely in cold forming. It is one of the best pressure

lubricants because it is virtually frictionless.

**Multiple-Station Header:** Generally a large cold forming machine that can include up to seven different die stations to perform a number of operations, including upsetting and extruding. Depending on part complexity, multi-station headers can produce 36,000 parts per hour with an automated, transfer sequence.

**Nib:** A small die insert made from tool steel or carbide.

**Open Die:** Used in cold forming to produce parts with long shanks that cannot be made on solid die machines. Stock feeds between the two halves of the open header die until it reaches the stock stop. The die then closes, grips the stock, and transfers it to a punching station. The wire is sheared during travel. The blank is then headed and the die returns to the feed station and reopens.

**Passivation:** A post-fabricating process that hastens the formation of the protective oxide film on stainless steels to prevent corrosion. Work is cleaned with a commercial degreaser or cleanser, then immersed in a nitric acid solution.

**Piercing Pin:** A special knockout pin designed to pierce hollow rivets, or act as part of the punch to form special hollow shapes.

**Precipitation Hardening:** A term used to describe a group of specialty stainless steels that offers a combination of strength and corrosion resistance unmatched by the austenitic,

ferritic or martensitic stainless steels. Also known as PH or age-hardening stainless grades. Carpenter PH grades include the Custom 450® stainless, Custom 455® stainless, and Custom 630 stainless.

**Punch:** (Also referred to as the hammer.) The movable heading machine component attached to the gate that forces the blank against the stationary die in upsetting and extruding. Usually two punches are used with a single die to produce a finished part on every other stroke of the machine.

**Quenching:** Rapid cooling of materials following heat treating. Specific methods include direct, fog, hot, interrupted, selective, spray or time quenching. Important in achieving structural changes in ferrous alloys, i.e., transforming austenite to martensite.

**Quill:** Another name for the heading machine’s cut-off die in which the wire stock is held prior to blank shearing.

**Recrystallization Temperature:** The temperature at which a new strain-free grain structure is produced from that existing in a cold worked metal.

**Shank:** The portion of a fastener beneath the head.

**Shear Cracking:** Cracks in the workpiece that appear at an angle of 45° to the direction of the applied load, and which are caused by shear stress.

**Solid Die:** A block of metal, usually made from tool steel or

including a special insert, that contains a cavity or cylindrical hole into which the blank is forced in the upsetting and extruding operations. Most heading is done using solid dies, also called closed dies. (See Open Die.)

**Stroke:** The action of the punch striking the blank or workpiece. Same as the term blow. The double-stroke heading process means two punches strike the blank in separate blows, but only one die is used.

**Superalloy:** (See High Temperature Alloy.)

**Tempering:** Reheating hardened steel dies or parts at relatively low temperatures to reduce stress. Usually accompanied by lower hardness.

**Tensile Strength:** (Also referred to as ultimate strength.) The point at which metal separates or tears apart under tension. Calculated by dividing the cross-sectional area of parts into the applied load at time of fracture. Tensile strength is the upper limit of the formability range; exceeding it causes cracking of parts during heading.

**Thread Rolling:** Opposite of cut threading. A rapid process in which threads are formed to a fastener blank as it is rolled between two dies. Rolled threads may be stronger than cut threads since, like cold forming, the metal is merely reshaped. Grain structure follows thread direction. This is a secondary operation except for bolt maker machines that include a thread rolling station.

**Toggle Header:** A machine that uses a toggle assembly, rather than a crank method, to drive the punch against the workpiece. The toggle header, used commonly to produce simpler parts, provides a mechanical advantage by delivering two blows per crankshaft revolution compared to one blow per revolution with crank headers.

**Ultimate Strength:** (See Tensile Strength.)

**Upsetting:** Application of force to the end of a metal wire or bar, contained between a punch and a die, to exceed the material's elastic limit (yield strength) to cause plastic flow. Synonymous with heading, or forming the head of a fastener.

**Warm Heading:** A forming method in which the wire is heated to a temperature, usually between 400° and 600°F, to improve its plasticity and formability before it enters the heading machine.

**Work Hardening Rate:** (Sometimes referred to as "cold working rate.") In cold working, the rate at which a metal becomes increasingly harder during cold-forming operations. Alloys with low work-hardening rates are more suitable for heading and cold forming.

**Yield Strength:** The point at which a metal begins to deform permanently, or plastic flow occurs.

## Further Reference Note

For more specific information on stainless, high temperature and other specialty alloys, visit us at our website, [www.carttech.com](http://www.carttech.com).

To contact your nearest Carpenter sales office call **1-800-654-6543**.

## Acknowledgments

Carpenter Technology Corporation gratefully acknowledges the contributions of the National Machinery Company, Tiffin, Ohio; STM Waterbury Headers, Inc., Waterbury, Connecticut, a subsidiary of SFM Corporation; and "Purchasing World" magazine.

Figures 2, 3, 5, 7, 9, 15, 16, 17 and 19 are reprinted with permission from Waterbury Farrel's "The Heading Story," published in 1966.

Figures 4, 6, 61, 63 and 64 are reprinted with permission from National Machinery's "Upsetting," published in 1971. Figures 8 and 18 are reprinted with permission from National Machinery's "Parts from Wire," published in 1970.

Figure 1 is courtesy of "Purchasing World" magazine, December 1983.

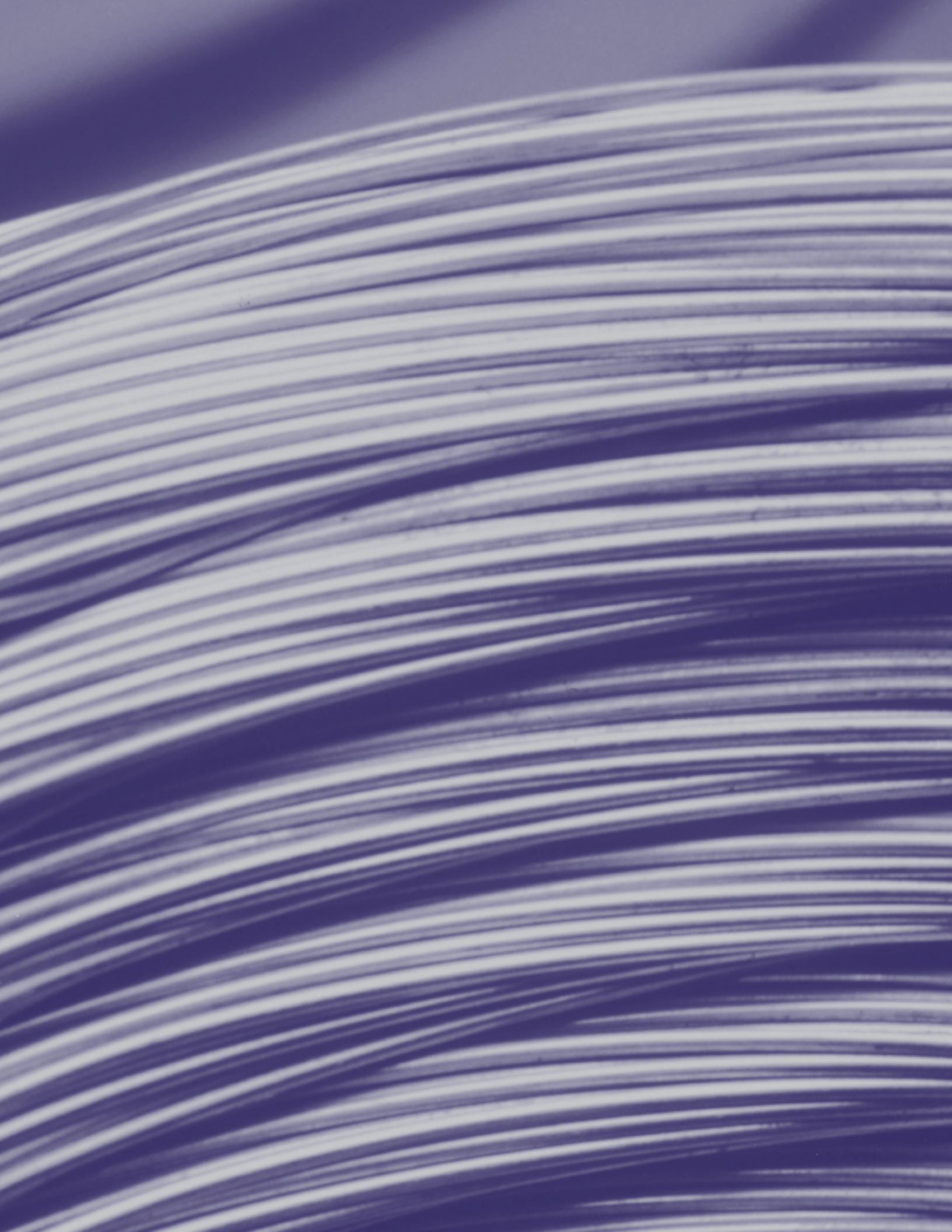

To reach your nearest U.S.  
Carpenter Service Center, call:

**1-800-654-6543**

This number will automatically connect  
you to the Service Center nearest you.

## Carpenter Specialty Alloys Service Worldwide

### **Toronto, Canada**

Carpenter Technology (Canada) Ltd.  
TEL: 905-564-5255  
In Canada: 800-268-4740  
FAX: 905-564-1909

### **Brussels, Belgium**

Carpenter Technology (Europe), S.A.  
TEL: 32-2-240-1840  
FAX: 32-2-240-1830

### **Redditch, England**

Carpenter Technology (UK) Ltd.  
TEL: 44-1527-512-200  
FAX: 44-1527-512-201

### **Maharashtra, India**

Kalyani—Carpenter  
Metal Centres Ltd.  
Mundhwa, Pune-36  
TEL: 91-20-681-9941  
FAX: 91-20-687-6898

### **Taipei, Taiwan**

Carpenter Technology (Taiwan) Ltd.  
TEL: 886-2-2757-7014  
FAX: 886-2-2757-6964

### **Singapore**

Carpenter Technology Asia Pacific Pte. Ltd.  
TEL: 65-738-2401  
FAX: 65-734-7983

### **Mexico**

Aceros Fortuna, S.A. de C.V.  
Tlalnepantla, Mexico  
TEL: 52-5-328-0946  
FAX: 52-5-392-5881

#### Mexico City (3 Branches):

Centro  
TEL: 52-5-542-4200  
FAX: 52-5-542-4881

Iztapalapa  
TEL: 52-5-670-8799  
FAX: 52-5-670-2208

Vallejo  
TEL: 52-5-328-0900  
52-5-328-0901  
FAX: 52-5-392-5973  
52-5-328-0915

Chihuahua  
TEL: 52-14-140-317  
52-14-142-911

52-14-146-924  
FAX: 52-14-135-843

Guadalajara  
TEL: 52-3-619-7444  
FAX: 52-3-619-2738

Monterrey  
TEL: 52-8-375-7621  
FAX: 52-8-375-6810

Puebla  
TEL: 52-22-494-044  
FAX: 52-22-494-830

Querétaro  
TEL: 52-42-161-400  
FAX: 52-42-169-195

Torreón  
TEL: 52-17-187-990  
FAX: 52-17-186-959

Toluca  
TEL: 52-211-8250  
FAX: 52-211-1542

Aceromex Atlas, S.A. de C.V.  
TEL: 52-5-328-0900  
FAX: 52-5-328-0915  
52-5-392-5973

## **Authorized Sales Agents**

### **Israel**

Aerniv Agencies Ltd.  
TEL: 972-3-644-2727  
FAX: 972-3-644-2728

### **Puerto Rico**

General Metals and Tools  
TEL: 787-789-8890  
FAX: 787-708-4197



Carpenter Technology Corporation  
Wyomissing, PA 19610 U.S.A.

Visit us at [www.cartech.com](http://www.cartech.com)